



**STANDARD**

**TITLE: STANDARD FOR BUSH CLEARANCE AND MAINTENANCE WITHIN OVERHEAD POWERLINE SERVIDUES**

REFERENCE  
**ESKASABG3**  
DATE: **MAY 2000**  
PAGE **1** OF **14**  
REVISION DATE:  
**MAY 2003**

REV  
**1**

COMPILED BY

FUNCTIONAL RESP.

AUTHORIZED BY

.....  
**Corporate Environmental Affairs**

.....  
**V Govender  
CEAM**

.....  
**T S Gcabashe  
CE (Designate)**

This document has been seen and accepted by:

**Management Board Environmental Steering Committee (MB-ESC)  
The Environmental Liaison Committee (ELC)**

**Contents**

	Page
1 Scope .....	2
2 Normative references .....	2
3 Definitions.....	2
4 Requirements.....	3
4.1 General requirements for all bush clearing of powerline servitude routes .....	3
4.2 Procedure to be followed in determining bush clearing requirements.....	7
4.3 Bush clearing requirements for new powerline construction projects .....	10
4.4 Bush clearing requirements for the maintenance of existing powerline servitudes .....	11
<b>Annexes</b>	
A Bush clearing checklist to determine actions required (see 4.2.2) .....	12
B Sketch plan for bush clearing specifications .....	13
C Minimum clearances and general servitude widths .....	14

## **1 Scope**

This standard sets out the manner in which all initial powerline route clearing and any subsequent vegetation maintenance is to be performed within all Eskom powerlines servitudes.

It sets the minimum standards for bush clearing and maintenance of all powerline routes and indicates Eskom's rights and responsibilities.

## **2 Normative references**

The following documents contain provisions that, through reference in the text, constitute requirements of this standard. At the time of publication the editions indicated were valid. All standards are subject to review and parties to agreements based on this standard are encouraged to investigate the possibility of applying the most recent revisions of the standards listed below. Information on currently valid national and international standards may be obtained from the Information Centre at Megawatt Park and Technology Standardization Department.

ESKADABD1:Rev.1, *Environmental management systems.*

ESKASAAL0:Rev.0, *The safe use of pesticides and herbicides.*

SCSASAAZ9: Rev.0, *Clearing and maintenance of servitude routes.*

ESKPBAAD4:Rev.0, *Herbicide Management.*

ESKPVAAZ1:Rev.2, *Environmental management programme (EMP) procedure.*

CO/P 015:Rev.0, *Servitude corridor bush clearing and maintenance procedure.*

CD/P 070, *Pruning and cutting of trees near energised power lines.*

OPR 6204:Rev.0, *Operating regulations for high-voltage systems (ORHVS).*

Commercial Timber Growers Guideline for: *Maintenance and management agreement in forest plantation areas and servitude areas* (available from Eskom's Legal department).

## **3 Definitions**

**3.1 commercial timber growers:** Timber growers, both individually or as represented by the Forest Owners Association, South African Wattle Growers Union or the South African Timber Growers Association and their personnel. (Commercial Timber Growers Guideline)

**3.2 environment:** The surroundings within which humans exist and that are made up of:

- a) the land, water and atmosphere of the earth;
- b) micro-organisms, plant and animal life;
- c) any part or combination of (i) and (ii) and the interrelationships among and between them; and
- d) the physical, chemical, aesthetic and cultural properties and conditions of the foregoing that influence human health and well-being. (National Environmental Management Act, 1998 (Act 107 of 1998))

**3.3 environmental management programme (EMP):** A programme that seeks to achieve a required environmental end state and describes how activities, that could have a negative impact on the environment, will be managed and monitored and impacted areas rehabilitated.

**3.4 plantation:** Any trees planted and managed by commercial timber growers for commercial purposes.(Commercial Timber Growers Guideline)

**3.5 servitude:** Eskom servitudes registered in the Deeds Office as well as rights obtained in terms of an agreement.

**3.6 weeds and invader plants:** Weeds and invader plants, as defined under Section 1 of the Conservation of Agricultural Resources Act, 1983 (Act 43 of 1983) and Government Notice R1048 of 25 May 1984 Part 2, or any list of invaders as may be agreed upon between Eskom and the Timber Industry or as identified by the Agricultural Research Council and the Plant Protection Research Institute (Handbook No.5 – Plant Invaders of Southern Africa).

## **4 Requirements**

### **4.1 General requirements for all bush clearing of powerline servitude routes**

The objective of powerline route bush maintenance is to ensure the safe mechanical and electrical operation of the powerline and to meet Eskom's legal, business and environmental obligations and to minimize the risk to affected landowners and the general public.

**4.1.1** The following clause in Eskom's Standard Servitude shall be adhered to

"No tree shall be allowed to grow to a height in excess of the horizontal distance of that tree from the nearest conductor of any powerline or to grow in such a manner as to endanger the line should it fall or be cut down".

**4.1.2** For all practical purposes, tree cutting shall be confined to the building restriction area as referred to in the servitude.

**4.1.3** In terms of the Occupational Health and Safety Act, 1993 (Act 85 of 1993), "The supplier or user of powerlines shall control vegetation in order to prevent it from encroaching on the minimum safety clearances of the power lines and the owner of the vegetation shall permit such control".

**4.1.4** The objective in clearing powerline servitudes of trees and bushes is to ensure the safe mechanical and electrical operation of the line and to change from incompatible to compatible vegetation.

**4.1.5** The scope of works and/or requirements for bush clearing shall be determined in accordance with the procedure set out in section 4.2.

**4.1.6** Bush clearing for new powerline projects shall be carried out in accordance with the standards set out in section 4.3.

**4.1.7** Bush clearing for existing powerline servitudes shall be carried out in accordance with the standards set out in section 4.4.

**4.1.8** All bush clearing that is to take place within a forest plantation shall conform to the Commercial Timber Growers Guideline: *Maintenance and Management Agreement in Forest Plantation Areas and Servitude Areas between Eskom and Commercial Timber Growers*.

**4.1.9** To promote the implementation of a three year programme for bush clearing (herbicide) contracts.

**4.1.10** In terms of Eskom's servitude agreement, Eskom (and/or its appointed contractor) has the right to enter and be upon the property at any time whether it is to perform work on the property itself, or to gain access to any adjacent property. However, Eskom will exercise due diligence in its attempts to notify the owner of any intention to enter the property to cut trees and bush and endeavour to obtain consent to the proposed work.

**4.1.11** In order to assist with access, Eskom may erect such gates as may be necessary, in consultation with the property owner. Under no circumstances shall access be gained by cutting or "dropping" fences. All gates shall be left closed and the Eskom servitude gates shall be securely locked at all times.

#### **4.1.12 Indigenous bush and trees**

- a) Various species of indigenous trees and bush on private land are protected by law (National Forest Act, 1998 (Act 84 of 1998)) in terms of which it is necessary to obtain a permit from the relevant authority in order to cut them.
- b) Provincial ordinances shall be adhered to where it is absolutely essential to cut protected indigenous trees. The necessary permits as well as the owner's written consent shall be obtained prior to commencement of any work.
- c) Where there is any doubt as to whether a tree specie is protected or not, the Department of Environmental Affairs and Tourism or the local Eskom environmental practitioner in the area shall be consulted.
- d) Indigenous trees and bushes that do not grow high enough to cause interference with the powerline or cause a fire hazard, shall not be cut down or trimmed.

#### **4.1.13 Herbicide use**

- a) The use of herbicides shall be in compliance with the terms of The Fertilisers, Farm Feeds, Agricultural Remedies and Stock Remedies Act, 1947 (Act 36 of 1947).
- b) In terms of the above Act, only a registered pest control operator may apply herbicides on a commercial basis. All application of herbicides shall be carried out under the supervision of a registered pest control operator.
- c) The Eskom Corporate Policy (ESKPBAAD4) and Standard (ESKASAAL0) on Herbicide use shall be adhered to.
- d) A daily register shall be kept of all relevant details of herbicide usage and such register maintained by the relevant Eskom custodian.

#### **4.1.14 General**

- a) Deep valleys and environmentally sensitive areas that do not allow vehicle access, or legally protected areas, shall not be cleared of vegetation provided that the vegetation poses no threat to the operation and reliability of the powerline. In the case of the construction of new powerlines a one metre "trace-line" may be cut through the vegetation for stringing purposes only and no vehicle access shall be allowed along the cleared "trace-line".
- b) Reasonable measures to prevent soil erosion shall be implemented at all times. If soil erosion does take place within the servitude area as a direct result of an act or omission by the land owner/user or Eskom, corrective measures, in consultation with the other party, shall be implemented and the cost borne by the party at fault.
- c) Rivers, watercourses and other water bodies shall be kept clear of felled trees, bush cuttings and debris. Where possible the integrity of riverbanks shall be maintained.

- d) Aesthetic consideration shall be taken into account where powerlines cross major roads and rivers or enter dense bush or woodland. An attempt will be made to ensure that all clearing will be performed in a manner so as to leave a screen of vegetation in the servitude on each side of the road or river or at the start of the dense bush or woodland.
- e) Trees, shrubs, grass, natural features and topsoil, that are not removed, shall be protected from damage during operations. Scalping of the earth, or any necessary disturbance, shall be allowed for access roads only.
- f) The specification for re-vegetation of disturbed areas will be issued on an area specific basis by Eskom.
- g) It shall be ascertained from the property owner concerned whether he/she wishes to retain the cut trees and bushes. If not, they shall be removed or disposed of or treated (chipping) in an appropriate manner to the satisfaction of the owner. Burning shall not be permitted under **any** circumstance.
- h) Where it is desirable to cut trees beyond the servitude building restriction width, the consent of the owner shall be obtained where no special agreement exists.
- i) Any damage to property, including but not limited to, crops, stock, fencing and gates, shall be compensated, repaired or replaced at the contractor's expense, to the satisfaction of Eskom and the landowner.
- k) Where possible, vegetation clearance for servitudes shall be performed so that the servitude boundaries are curved and undulating (narrow at tower positions and wide at the lowest point of the conductor). See figure 1 below.

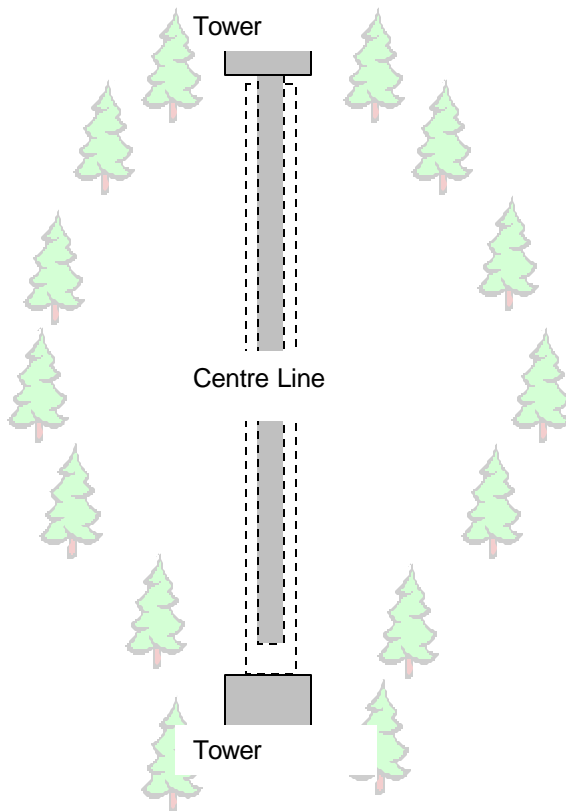

**Figure 1 (refer to section 4.1.14.k)**

- l) The contractor/Eskom shall:
- 1) remain on all existing roads and tracks and within the servitude area and not deviate therefrom;
  - 2) keep Eskom gates locked and leave property owners' gates closed or as agreed to in writing between Eskom and the land owner;
  - 3) not interfere with the property owners' activities;
  - 4) request permission for the use of water;
  - 5) provide appropriate toilet facilities;
  - 6) not make fires;
  - 7) not litter;
  - 8) not drop fences;
  - 9) not collect firewood without consent; and
  - 10) not disturb or remove stones/rock from the site (i.e. archaeological and heritage sites).

**4.1.15 Warranty shall be obtained from the contractor that**

- a) He or she knows and understands the dangers involved in clearing bush in or around powerlines and the dangers of the spread of fire.
- b) He or she understands and will comply with Eskom procedures.
- c) He or she understands that he/she must be authorized by the relevant Eskom representative, in writing in terms of Eskom's ORHVS regulations. Eskom must declare him or her competent.
- d) He or she is a competent person and is a registered pest control operator or shall ensure that any chemical clearing shall be done under the supervision of a registered pest control operator.
- e) He or she is able to and shall comply with, all legislation pertaining to the nature of the work to be done and all things incidental thereto.
- f) He or she shall appoint a land owner liaison officer, who shall personally contact all affected land owners and users telephonically or in writing and obtain their permission before any trees or bushes are cut, regardless of any previous arrangements or agreements. This shall not be applicable in the case where Eskom has undertaken this requirement.
- g) For all affected powerlines a list of property owners shall be supplied, by Eskom, to the contractor to enable him to obtain the owners' consent.

**4.2 Procedure to be followed in determining bush clearing requirements**



An environmental management programme (EMP) shall be developed and implemented for each bush clearing contract awarded or internal project undertaken. This shall be done for new powerline construction projects as well as for existing powerline servitude maintenance. The following steps shall be undertaken in preparing the EMP for the required bush clearing operation:

**4.2.1 Collection of environmental information on the powerline route**

The following information about the powerline shall be collected.

No.	Item	Yes	No
1	Map of powerline route (either a 1:50,000 map with annotated powerlines and towers, spanning plans / profiles, compilation plans, or route map)		
2	Eskom's legal requirements (servitude conditions, wayleave and other contract conditions)		
3	Veld fire risk areas (that affect the quality of supply)		
4	Vegetation types along the powerline route		
5	Soil types along route		
6	Herbicide register (of chemicals used on the servitude in the past)		
7	Register of past contracts or work undertaken in terms of bush clearing		
8	Affected landowners' property details, names, addresses, telephone numbers and land use. Complaints / communication register with affected landowners. A record of their "Special conditions" with regard to bush clearing.		
9	Sensitive environmental areas (wet lands, private game farms, nature reserves, national parks, natural heritage sites, archaeological / historical sites, endangered / protected species {fauna & flora} forest plantations, cultivated lands, indigenous forests etc.)		
10	Technical specifications and dimensions regarding tower types		
11	A register of the number of fires, flash-overs (as a result of vegetation) and interference by vegetation that resulted in reduced quality from supply of the powerline in question		

All this required information should be collected before proceeding further.

**4.2.2 Identify and/or predict the bush clearing problems and actions to be taken to solve them**

Have all the problems associated with bush clearing on the powerline route been identified?

- a) The existing or potential problem areas shall be indicated on a sketch plan (see annex B) based on a site inspection of the powerline route (existing or proposed). For each issue identified, the action to be taken shall be determined.
- b) Action to be taken shall be based on the information obtained in **4.2.1** and shall conform to the standard set out in sections 4.3 and 4.4 depending on whether the bush clearing is for a new powerline construction project or maintenance of an existing powerline servitude respectively.
- c) The actions to be taken shall be based on scientific and technical knowledge and experience. The actions shall strike a balance between ensuring the protection of the environment, minimal damage to landowner's property and shall ensure the integrity of the powerline's quality of supply

- d) The consequences of each action taken shall be determined and justified.
- e) The assessment results shall be documented (see annex A).
- f) Once an assessment of the powerline route has been undertaken and the required actions are determined, these shall be discussed with the affected landowners. Their concerns with regard to the proposed actions shall be addressed.

Once the assessment of the powerline route has been undertaken it shall be integrated into the project documentation (contract scope of work or work instruction).

#### **4.2.3 Integration into the project/operational systems, documentation and contracts**

- a) For each action required, detailed specifications (see sketch plan in annex B) shall be drawn up including:
  - 1) the site to be cleared (a description of the property and/or powerline).
  - 2) the area to be cleared (the width to be cleared under powerline, access road, servitude width and the area around structures).
  - 3) the height to be cleared (for cutting of grass and reeds, access road, strip under powerline, servitude width as well as trimming of trees).
  - 4) other requirements (property owners' special requirements)
  - 5) removal of vegetation (requirements for the removal or chipping or cutting-up and stacking of the cut vegetation).
  - 6) timing (when bush clearing is to take place ie time of year, day and time – if required).
  - 7) notification (all land owners/users shall be notified and their consent obtained before entering property to carry out bush clearing, and any other special requirements).
- b) The actions in 4.2.3(a) constitute the EMP and it shall be integrated into the scope of work or work description as part of tender documents and subsequent contracts or a work instruction when undertaken by Eskom staff.

#### **4.2.4 Appointment of Project Manager and award of contract**

- a) Once the EMP has been prepared and the contract scope of works, or work instruction determined, a project manager shall be appointed, an enquiry shall be prepared and issued and a contract awarded when external contractors are used, or a work instruction issued when the work is to be done by Eskom staff, and the bush clearing implemented. All contracts for bush clearing shall be in terms of Eskom's commercial requirements.
- b) The project manager shall:
  - 1) manage the contract in terms of the contract or work instruction requirements;
  - 2) resolve disputes between land owners and those carrying out the bush clearing;
  - 3) report all incidents in terms of the Group's standard for the reporting and investigation of incidents; and
  - 4) ensure that those carrying out the bush clearing understand the requirements of the contract/work instruction.



- c) The project manager shall inform the relevant Customer Service Centre Manager, in the case of Distribution, and the applicable Regional Manager in the case of Transmission, of the proposed bush-clearing project. The following details shall be furnished to them: the project location, the time period, the project manager and contractor's names and contact details.

#### **4.2.5 Monitoring and audit**

- a) **Monitoring:** There shall be a monitoring programme in place to not only ensure conformance with the EMP through the contract/work instruction specifications but also to monitor environmental issues and impacts that have not been accounted for in the EMP, that are, or could result in significant environmental impacts for which corrective action is required. Monitoring shall form part of the contract or work instruction. The period and frequency must be stipulated. The project manager shall ensure that the monitoring is carried out.
- b) **Audit:** The requirement for an audit shall be stipulated in the contract or work instruction. It shall be undertaken within a specified period after completion of the work but before the contract is signed off. The audit shall be used to identify non-conformances for which corrective action shall be taken. Corrective actions shall take place before the contract is signed off. The audit shall also be used to identify findings that can be used to improve further EMPs for bush clearing. The auditor shall be appointed by the project manager.

**4.3 Bush clearing requirements for new powerline construction projects**

a) The minimum standards to be used for bush clearing for new powerline construction are listed in the table below. These specifications shall be used in conjunction with the EMP that has been compiled.

<b>Item</b>	<b>Standard</b>	<b>Follow up</b>
Centre line of proposed powerline	Clear to a maximum (depending on the tower type and voltage) of an 8 m wide strip of all unwanted vegetation along the centre line. Vegetation to be cut within 100 mm of the ground. Treat stumps with herbicide.	Re-growth shall be cut within 100 mm of the ground and treated with herbicide as necessary.
Inaccessible valleys (trace line)	Clear a 1 m strip for access by foot only for the pulling of a pilot wire by hand.	Vegetation not to be disturbed after initial clearing – vegetation to regrow.
Access road	Clear a maximum (depending on the tower type and voltage) 5 m wide strip for vehicle access within the maximum 8 m width, including de-stumping/cutting stumps to ground level, treating with a herbicide and re-compaction of soil.	Re-growth to be cut at ground level and treated with herbicide as necessary.
Proposed tower position and Proposed support/stay wire position	Clear all vegetation within proposed tower position and within a maximum (depending on the tower type and voltage) radius of 5 m around the position, including de-stumping/cutting stumps to ground level, treating with a herbicide and re-compaction of soil.	Re-growth to be cut at ground level and treated with herbicide as necessary.
Indigenous vegetation within servitude area (outside of the maximum 8 m strip)	Area outside of the maximum 8 m strip and within the servitude area, selective trimming or cutting down of those identified plants posing a threat to the integrity of the proposed powerline.	Selective trimming
Alien species within servitude area (outside of the maximum 8 m strip)	Area outside of the maximum 8 m strip and within the servitude area, cut all vegetation within servitude area and treat with appropriate herbicide.	Cut and treat with appropriate herbicide.

**4.4 Bush clearing requirements for the maintenance of existing powerline servitudes**

a) The minimum standards to be used for bush clearing for existing powerline maintenance are listed in the table below. These specifications shall be used in conjunction with the EMP that has been compiled.

<b>Item</b>	<b>Standard</b>	<b>Follow up</b>
Centre line of existing powerline	Clear a maximum (depending on the tower type and voltage) of an 8 m strip of all unwanted vegetation (all alien and invader vegetation and trees that could grow and interfere with the powerline or could make contact with conductors or structure in the event of falling over) along the centre line. Vegetation to be cut within 100 mm of the ground. Treat stumps with herbicide.	Re-growth shall be cut within 100 mm of the ground and treated with herbicide as necessary.
Inaccessible valleys	No clearing	No clearing
Access road	Maintain a maximum (depending on the tower type and voltage) 5 m wide strip for vehicle access, including de-stumping/ cutting stumps to ground level, treating with a herbicide and re-compaction of soil.	Re-growth to be cut at ground level and treated with herbicide as necessary.
Tower position and support/stay wire position	Clear all vegetation within proposed tower position and within a maximum (depending on the tower type and voltage) radius of 5 m around the position, including de-stumping /cutting stumps to ground level, treating with a herbicide and re-compaction of soil.	Re-growth to be cut at ground level and treated with herbicide as necessary.
Indigenous vegetation within servitude area (outside of the maximum 8 m strip)	Selective trimming or cutting down of those identified plants interfering or posing a threat to the integrity of the powerline.	Selective trimming
Alien species within servitude area (outside of the maximum 8 m strip)	Cut all vegetation within servitude area and treat with appropriate herbicide.	Cut and treat with appropriate herbicide.

**Annex A**  
 (normative)

**Bush clearing checklist to determine actions required (see 4.2.2)**

Draw a sketch (see annex B)

no.	Issue	Grass	Declared weed	Invader	Reeds	Sugar cane	Forest plantation	Other	Indigenous	Action to be taken	Justification
	Access road										
	Tower position										
	Stay wire position										
	Under and 2 m beyond outer phases										
	Within servitude/ wayleave area										
	River crossings vegetation										
	Road crossings vegetation										
	Land owner/user requirements										
	General comments (erosion, soil type)										



**Annex B**  
(normative)

**Sketch plan for bush clearing specifications**

**B.1 Sketch plan for bush clearing along powerline servitude**

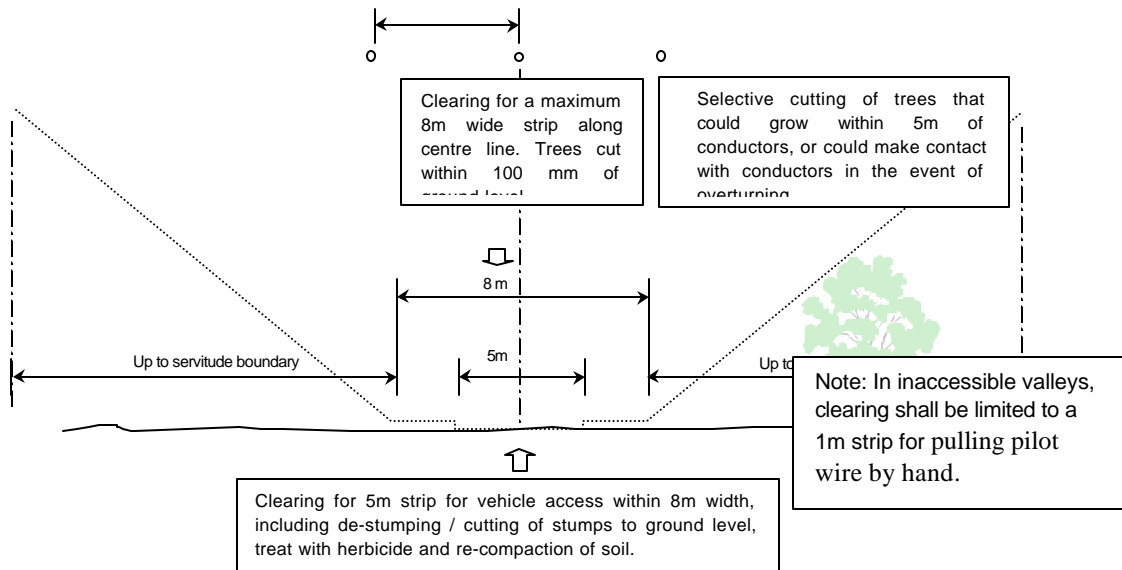

**B.2 Standard for all vegetation clearance at tower positions**

Clear all vegetation within proposed / existing tower position and within a maximum (depending on the tower type and voltage) radius of 5m around the position, including de-stumping / cutting stumps to ground level, treating with a herbicide and re-compaction of soil.

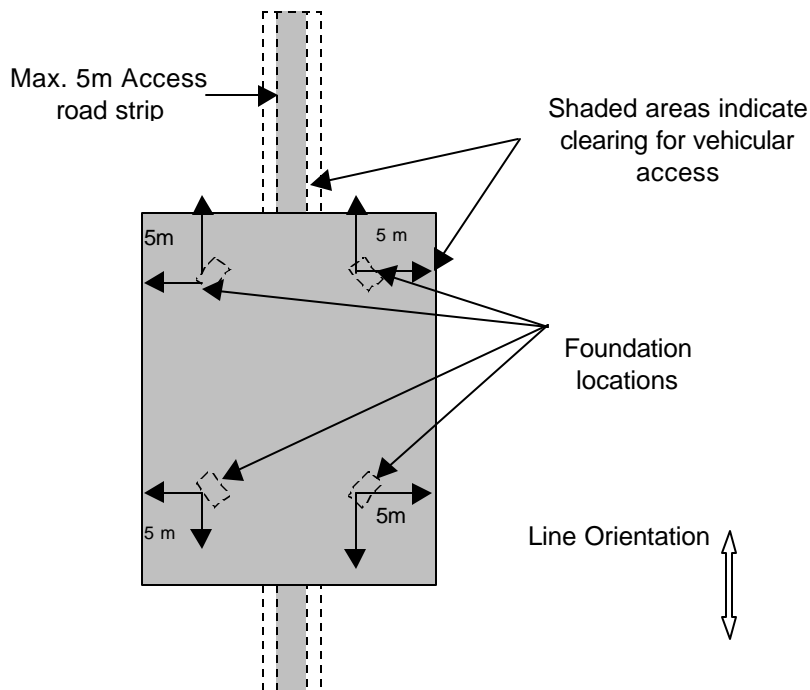

**Annex C**  
(normative)

**Minimum clearances and general servitude widths**

Maximum voltage	Minumum safety clearance (OHSA, No. 85 of 1993)	Servitude building restriction widths (measured from the centre line of the powerline) *
11 kV	0,20 m	9 m to 11 m
22 kV	0,32 m	11 m
88 kV	1,00 m	11 m
132 kV	1,45 m	15,5 m
275 kV	2,35 m	22 m to 23,5 m
400 kV	3,20 m	23,5 m to 27,5 m
765 kV	5,50 m	40 m
533 kV (d.c.)	3,70 m	15 m
Cross rope suspension		27,5 m

\* Refer to the powerline deed of servitude or other agreement for the exact dimension of the powerline servitude width in question.