



APPLICATION FOR AN ELECTRICITY GENERATION  
LICENCE IN TERMS OF THE ELECTRICITY REGULATION  
ACT, 2006 (ACT NO. 4 OF 2006).

Please return completed form to:

HOD: Electricity Licensing and Compliance  
National Energy Regulator of South Africa  
Kulawula House, 526 Vermeulen Street  
Arcadia, 0083  
Pretoria

Or:

HOD: Electricity Licensing and Compliance  
National Energy Regulator of South Africa  
P.O. Box 40343  
Arcadia  
0007

Tel (012) 401 - 4600  
Fax (012) 401 - 4700

**SECTION A            PARTICULARS OF APPLICANT**

A1     Full name of applicant (business name) and business registration number

**Eskom Holdings SOC Limited  
Reg. No. 2002/015527/30**

A2     Address of applicant, or in the case of a body corporate, the registered head office

**Physical address  
Megawatt Park  
Maxwell Drive  
Sunninghill  
Johannesburg  
2196**

**Postal address  
P O Box 1091  
Johannesburg  
2000**

A3     Telephone number of applicant

**(011) 800 8111**

A4     Fax number of applicant

**(011) 800 3111**

A5     Email address of applicant

A6     Contact person

First name

Surname

Telephone No

Mobile No

Fax No.

Email address

A7     Legal form of applicant

## **Company**

### **Note to Section A**

- 1) State whether the applicant is a local government body, a juristic person established in terms of an act of parliament, a department of state, a company or other legal body.

#### **Eskom is a State Owned Company (SOE)**

- 2) If the applicant is a local government body, attach a copy of the proclamation establishing such body. Where the applicant is a company, the full names of the current directors and the company registration number are required.

#### **Directors/Board members:**

**Eskom Holdings SOC Limited Registration Number 2002/015527/30**

**SECTION B                    COMMENCEMENT DATE OF LICENCE**

B1      Desired date from which the licence (if granted) is to take effect

**March 2022**

**Note to Section B**

- 1) The normal processing time for a licence application is 120 days once all relevant information has been provided and there are no objections received.
- 2) If the applicant intends operating more than one generation station under the proposed licence, please complete separate application forms for each generation station.

**SECTION C                    PARTICULARS OF PROPOSED GENERATION STATION**

C1     Name of generation station

**Melkhout Battery Energy Storage System**

C2     Geographical location of generation station (please attach maps)

**34°00'00"S 24°47'01"E**

**Please refer to Appendix 1**

C3     Address of generation station

**Humansdorp  
Eastern Cape**

C4     Contact person at generation station

**There have not been any appointments made at the station as the project is still in the procurement phase. Below are the contact details of the Dx Executive responsible for the execution of the project.**

First name and Surname

Telephone No

Mobile No

Fax No

Email address

C5     Type of generation station (thermal, nuclear, hydro, pumped storage, gas turbine, diesel generator or other)

**Other – Battery Energy Storage System - Electrochemical**

C6     Expected commissioning date for a proposed generation station or storage facility at which the station/facility was commissioned (if an existing station).

**Start Date of Construction -            March 2022**

**Commercial Operational Date-        September 2022**

C7     The installed capacity (existing and/or planned) of each unit within the generation station (MW)/(MWh)

**35 MW - Maximum charging and discharging capacity**

**140 MWh storage capacity**

- C8 Maximum generation capacity (MW) expected to be available from the generation station and energy to be produced (MWh) over the next 5 years of operation. These estimates should be based on modelling of how the power station will fit into the demand profile of its customers, taking into account the least cost energy purchase consideration and demand management options of customers.

YEAR	Max MW	Total MWh	Own use MWh	Export (Sales) MWh
1	35	51100	N/A	51100
2	35	51100	N/A	51100
3	35	51100	N/A	51100
4	35	51100	N/A	51100
5	35	51100	N/A	51100

- C9 Estimate of the energy conversion efficiency of the generation station.

**This is an energy storage facility with a charge to discharge efficiency of 90%.**

- C10 Expected future life of the generation station/storage facility.

**Battery Life - 20 years with augmentation (addition of cells to supplement lost capacity)**

**SECTION D**

**PARTICULARS OF LONG TERM ARRANGEMENTS  
WITH PRIMARY ENERGY SUPPLIERS**

D1 Name of primary energy supplier/s (mining house, colliery or other fuel supplier)

**This is a Battery Energy Storage System (BESS) and it will be supplied by electricity from the local electricity authority.**

**Name of local electricity distribution authority – Cape Coastal Cluster**

D2 Particulars of the contractual arrangements with primary energy supplier.

**Wheeling is not applicable. The Cape Coastal Cluster will supply, own and maintain the BESS.**

Notes to Section D

- 3) Please provide brief particulars of any long term agreements entered into with local electricity supply authority and copies of such contracts (Signed Electricity Supply Agreements).

**N/A – local supply authority owns, supplies and operates the facility.**

## SECTION E MAINTENANCE PROGRAMMES AND DECOMMISSIONING COSTS

E1 Details of any proposed major maintenance programmes, including the expected cost and duration thereof, covering the next six years. Project proposals to state the expected availability, planned outage rate and forced outage rate of the plant over the first five years of operation.

**Availability: 90%**  
**Planned outage rate: 7%**  
**Forced outage rate: 3%**

E2 Details of any major decommissioning costs expected during the life span of the power station and provided for in the project feasibility study.

**The industry has not reached a point of maturity to accurately determine disposal costs for long term battery storage. Existing references, industry standards cannot provide an accurate guide for recycling and disposal.**

**We refer you to the following industry standard regarding the above:  
*Lazard's Levelized Cost of Storage Analysis – Version 6.0***

E3 Details of major generation station expansion and modifications planned for in the feasibility study (Dates, Costs in Rands (state year) and description)

Key milestones								Remarks
	[Package 1]		[Package 2]					
	Skaapvlei		Lot A - Melkout		Lot B - Pongola & Elandskop			
	Forecast/ Actual Start	Forecast/ Actual Finish	Forecast/ Actual Start	Forecast/ Actual Finish	Forecast/ Actual Start	Forecast/ Actual Finish		
Issue bidding document to the market	29-Mar-21	29-Mar-21	29-Mar-21	29-Mar-21	29-Mar-21	29-Mar-21	Issue to market on 29 March 2021. Extension of bid period has been extended to 1. Skaapvlei closing 14 June 2021 2. Package 2 closing 15 June 2021 3. Package 3 closing 21 June 2021 4. * EMPPr Approved on 19 June 2020 for Elandskop and Pongola sites	
Closing of bids from the market	14-Jun-21	14-Jun-21	15-Jun-21	15-Jun-21	15-Jun-21	15-Jun-21		
Opening of bids (incl stamping of files)	14-Jun-21	22-Jun-21	15-Jun-21	23-Jun-21	15-Jun-21	23-Jun-21		
Evaluation of Bids (incl No Objection from Bank)	22-Jun-21	14-Sep-21	23-Jun-21	16-Sep-21	23-Jun-21	16-Sep-21		
Evaluation Report Appr. (ETC, IFC & Board)	14-Sep-21	04-Oct-21	16-Sep-21	06-Oct-21	16-Sep-21	06-Oct-21		
Obtain NERSA Licenses	30-Dec-21	30-Dec-21	30-Dec-21	30-Dec-21	30-Dec-21	30-Dec-21		
Contract Award & Effective Date (incl. vendor registration)	30-Dec-21	25-Jan-22	30-Dec-21	25-Jan-22	30-Dec-21	25-Jan-22		
EMPPr(DEF) announces decision)	03-Mar-22	03-Mar-22	15-Mar-22	15-Mar-22	19-Jun-20 A	19-Jun -20 A		
Long Lead Items (incl. Delivery to site)	25-Jan-22	18-Jul-22	25-Jan-22	27-May-22	25-Jan-22	27-May-22		
Construction (incl. Commissioning & COD)	15-Mar-22	14-Nov-22	15-Mar-21	11-Sep-22	25-Jan-22	11-Sep-22		

**The table above describes a high level activity schedule for the Melkout project. This breakdown as well as costs involved for the project in its entirety are included in detail in Section 9 and Section 11 of Appendix 3 – Feasibility Study Report.**



## **SECTION F                    CUSTOMER PROFILE**

F1      Particulars of the person or persons to whom the applicant is providing or intends to provide electricity from the generation station

**National Electricity Grid**

F2      Network connection details (connection points, voltages, wheeling arrangement, single line diagram)

**Connected at Melkhout Substation**

**Please refer to Appendix 2**

F3      Provide summary details of Power Purchase Agreements with customer including purchasing price etc. (Please attach Power Purchase Agreements).

**N/A - Supply to Eskom**

Notes to Section F

- 4) For example, supply to ESKOM or supply to local government distribution system. Please include the details of power purchase agreements entered into and the price structure of the contract.

**N/A**

**SECTION G FINANCIAL INFORMATION**

G1 Submit projections of and current statements of the accounts in respect of the undertaking carried on by the applicant, showing the financial state of affairs of the most recent period, together with copies of the latest audited annual accounts where such have been prepared.

**Please refer to the following link for Eskom’s Integrated Report:**

**<https://www.eskom.co.za/ourcompany/investors/integratedreports/Pages/AnnualStatements.aspx>**

G2 Submit annual forecasts for the next five years of costs, sales and revenues generated by the project, stating the assumptions underlying the figures.

**See G3 Below**

G3 Estimates of net annual cash flows for subsequent periods (5 years; 10 years; 15 years) sufficient to demonstrate the financial security and feasibility of operating the generation station/storage facility

**Table A: Cash flow for capital in R’millions**

Phase 1	Total	2022	2023
<b>Project CAPEX (R'm)</b>			
Plant CAPEX	4 794	4 485	309
ODC	187	93	93
Forward Cover	55	-	55
<b>Total</b>	<b>5 036</b>	<b>4 579</b>	<b>457</b>

**Table B: Total Operating costs for a 20 year period in R’millions**

Phase 1	Total
<b>Operating cost (R'm)</b>	<b>20 years</b>
Fixed O&M Cost	2 572
Variable O&M Cost	4 979
	<b>7 551</b>

**The facility will be used for ancillary services, energy services and other network support capabilities.**

**The project lifecycle (capital & operating) costs incurred over the life of the project will be recovered through the tariff application via the MYPD process.**

**The LCOE, Cost Benefit and Breakeven Analysis of the Project in its entirety (Phase 1 and Phase 2), is described and calculated in Section 9 of Appendix 3 – Feasibility Study.**

G4 Project financing: Who will finance the project, how is funding split between debt and equity, and what is the terms and conditions of the funding agreements.

**Below is an overall breakdown of the BESS Project Funding in its entirety. It includes the spend on all the sites as part of Phase 1 and Phase 2 of the project. Further details on the loan agreements are provided in Section 10 of Appendix 3 – Feasibility Study.**

**Table 12: Funding breakdown**

**Notes to Section G**

- 1) The financial projections should be based on a production plan for the generation station and the revenue generated by participating in the electricity market and by bilateral contracts (Power Purchase Agreements) with customers. Reference to the latest version of National Integrated Resource Plan (IRP) is required to demonstrate that the proposed power purchase agreement is the least cost solution available to the electricity purchaser.

**The BESS capacity has been determined against Storage capacity allocated for 2029 in IRP 2019. The award of the determination has been supported by a feasibility study reviewed by the DMRE and concurred with by NERSA. Appendix 4.**

## SECTION H HUMAN RESOURCES INFORMATION

H1 Submit details of the number of staff and employees and their categories in the service of the applicant at the generation station or storage facility and in any support services separate from the generation station. Also provide information regarding relevant qualifications and experience in critical areas e.g. Professional registration (Engineering Council of South Africa – ECSA), Government Certificate of Competency.

**The installation of the BESS will be at an existing Eskom Distribution Substation and it is not envisaged that any extra staff will be required by Eskom.**

**There will be a 5 year O&M contract signed with the successful bidder for the design, supply and installation and commissioning.**

**SECTION I****PERMISSION FROM OTHER GOVERNMENT  
DEPARTMENTS OR REGULATORY AUTHORITIES**

- 11 What progress has been made to obtain the required permits and approvals for the generation project? Please provide copies of permits issued by the relevant environmental and safety agencies in respect of the operation of the generation station.

<b>Regulating Authority</b>	<b>Permit or Approval</b>	<b>Applicable legislation or Code Of Practice</b>	<b>Status Report</b>
Department of Environmental Affairs	Environmental Authorisation (EA)	National Environmental Management Act (NEMA)	Approved – Issued on 4 <sup>th</sup> February 2020
NERSA	Compliance to Grid Code	Grid Code for BESF v5.2	Commissioning of BESF will be in accordance to approved to Grid Code. Compliance to Grid Code will be tested for during commissioning.
DMRE	Determination against storage capacity allocation from 2029 from IRP 2019	In accordance with section 10(2)(g) of the Electricity Regulation Act 4 of 2006.	Determination concurred by NERSA on 25th February 2022
Ministry of Public Enterprises	PFMA Authorisation	Public Finance Management Act (PFMA)	Approved for Phase 1 – Issued on 21 <sup>st</sup> November 2019

**SECTION J**

**BROAD-BASED BLACK ECONOMIC EMPOWERMENT**

J1 Please provide information in terms of the following categories

COMPONENTS	POINTS	0.5	0.75	1
Direct Empowerment	Black Ownership	10% to <20%	20% to 50%	>50%
	Black Management	20% to <35%	35% to 50%	>50%
	Black Female Management	1% to <5%	5% to 10%	>10%
Human Resource Development	Black Skilled Personnel as % of payroll	20% to <35%	35% to 50%	>50%
	Skills Development Programs as % of payroll	1% to <5%	5% to 10%	>10%
	Employment Equity i.e. Women Representation	20% to <35%	35% to 50%	>50%
Indirect Empowerment	Procurement from Black/BEE Suppliers	20% to <35%	35% to 50%	>50%
	Enterprise Development i.e. Monetary Investment or quantifiable non-monetary support in SMME with BEE contributions as % of Net Asset Value/ EBITDA/Total Procurement	10% to <20%	20% to 25%	>25 %
	Industry specific initiatives to facilitate the inclusion of black people in the sector as % of net profit	1% to <5%	5% to 10%	>10%
NERSA's Discretionary Points	Based on skills transfer and fulfilment or acceleration of other national objectives e.g. employment of disabled personnel robust implementation of mechanisms to verify the BEE status of suppliers reported under preferential procurement and utilization of DTI approved accreditation agencies and so on.	1% to <5%	5% to 10%	>10%

**Below is a brief description on the requirements of bidders for Phase 1 of the BESS Project.**

The application of PFMA and PPPFA exemption was granted in terms of PPPFA of 2000, except for regulation 12 and 14 that no longer exist in the 2017 regulation. The approval of the PFMA was only for Phase 1 with specific requirements to be met on application for Phase 2. This approval is also subject to a condition that the principles of section 217 (1) of the Constitution are complied with. Phase 2 in terms of the PFMA approval, amongst others requires a feasibility study to be conducted detailing technical opportunities for repowering and repurposing of the coal fired powers stations to be decommissioned.

## **Localisation**

### Procurement Spend within South Africa

Based on the high-level market sounding exercise Eskom conducted, Eskom has estimated that at least 40% of the Project value are locally manufactured and / or services that can be locally provided in South Africa,

Bidders (OEMs/EPC Contractors) are required to provide a written confirmation by completing the SDL&I Matrix Form to indicate that at least a minimum of 20% of the proposed contract value will represent Procurement Spend within South Africa. This will consist of subcontracting a minimum of 20% of the total contract value to previously disadvantaged groups and associated skills development. The Bidders can achieve compliance to this local procurement spend requirements through the SDL&I and BBBEE programs that already exists as means of facilitating Social and Economic sustainability.

## **Skills Development**

Skills development targets will be negotiated in terms of the Standard for Developing Skills through Infrastructure Contracts published by the Construction Industry Development Board (“the CIDB Skills Standard”).

The skills development calculation will be based on the class of construction works for Electrical Engineering works (infrastructure) and Civil Engineering works (CE), which is 0.25% of the total contract value.

The skills candidates may be developed directly by the successful bidder (Contractor) or through the bidder’s own supply network, or via Sector Education and Training Authority (SETA) accredited training providers.

Skills candidates shall be sourced from unemployed youth, matriculates from local areas, graduates from FET (Further Education and Training) colleges and universities. These candidates shall also be representative of the population demographics of South Africa.

Bidders are required to indicate the proposed number of persons to be trained per skills development requirements as per the Skills Development Compliance Matrix table provided within the bid document.

## Job Creation

Job Category per site	No. of jobs proposed by the Bidder per site
Unskilled workers	
Semi-Skilled	
Skilled	
Staff (supervisory/management)	
Total number of jobs to be created as a result of this contract	

Job creation proposal by bidders does not form part of the evaluation criterion. It is however, part of Eskom's contribution towards the Government's job-creation initiatives and therefore bidders are required to support the socio-economic imperative that seeks to empower local communities surrounding the areas where construction activities are conducted. These include the utilisation of local labourers from the area within which the project is taking place. All bidders are therefore required to propose to Eskom a resource plan for the work or number of jobs to be sourced from surrounding local communities.

## Industrialisation

In order to promote local capability and industrialisation in South Africa bidders are requested to submit, with their bids, the following:

A comprehensive plan on knowledge transfer in terms of Operations and Maintenance capabilities to Eskom employees which includes battery maintenance to ensure systematic and upkeep of battery power output.

A plan is also required to build local capacity and skill among the local contractors that will be incorporated into their value chain. Although Phase 1 of the project was based on the CSDP framework, the second phase will utilise the NIPP as a strategic policy lever to advance local technological advancement. This will require a commitment by contractors on final negotiation with the Dtic, The NIPP Government framework requires that on any contract with an in port value of \$5 million or equivalent and above that the winning bidder negotiate at least 30% of that value for local social economic development in terms of local skill and industrial development in SA.



## **Broad Based Black Economic Empowerment**

In respect of the Contractor being an international company without a B-BBE certificate, they will be not be excluded from the bid evaluation process however they will score 0 points on B-BBEE. Where the main contractor is a South African company, they will be required to submit a valid Broad-Based Black Economic Empowerment certificate, which is either a SANAS Accredited BBBEE certificates for transactions more than R50 million or valid sworn affidavit (DTI Template) will be required for transactions below R50 million.

## **SECTION K            ADDITIONAL INFORMATION**

Provide any other relevant information related to this application.

### **World Bank Funding**

In the process of securing funding for the Medupi coal-fired Power Station, Eskom approached the World Bank (WB). In the ensuing discussions, commitments were made to the WB that Eskom would pursue renewable energy projects, and concessionary loans were granted to Eskom in order to diversify its energy mix. On the 13 October 2017, Eskom proposed to the WB and AfDB the 1440 MWh distributed Battery Energy Storage System (BESS) with 60 MW distributed Solar Photo Voltaic (PV) project be installed in its distribution networks and substations as the most suitable solution to meet the Funder's criteria.

Eskom defaulting on the loan conditions has negative implications with the bank:

- Withdrawal of funding for the BESS and other related projects by the Funders
- Further delays for timeous execution and commissioning of the project
- Potential bidders have submitted their bids and this will have a negative reputational damage to Eskom as the total bidding process will have to be cancelled.

**SECTION L                    DECLARATION**

On behalf of the applicant, I hereby declare that:

- (a) the applicant shall at all times comply in every respect with the conditions attached to any licence that may be granted to the applicant;
- (b) the applicant shall at all times comply with lawful directions of the National Energy Regulator of South Africa;
- (c) the information provided by me on behalf of the applicant is accurate and complete in all respects; and
- (d) I am authorised to make this declaration on behalf of the applicant.

Signed:

--

Full name(s) of Signator(y/ies):

<b>Monde Bala</b>	
-------------------	--

Position held (if the applicant is a company, co-operative, partnership, unincorporated association or any other body corporate):

<b>Group Executive – Eskom Distribution</b>	
---	--

Date:

--

## Appendix 1      Locality Map

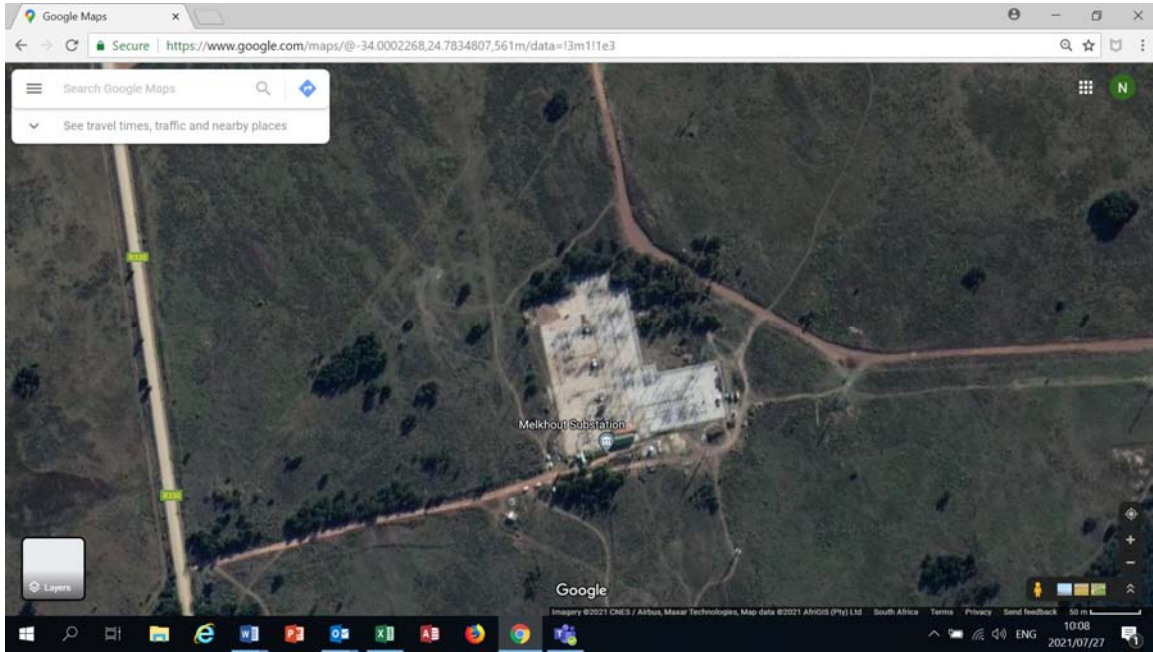

# Appendix 2 Single Line Diagram

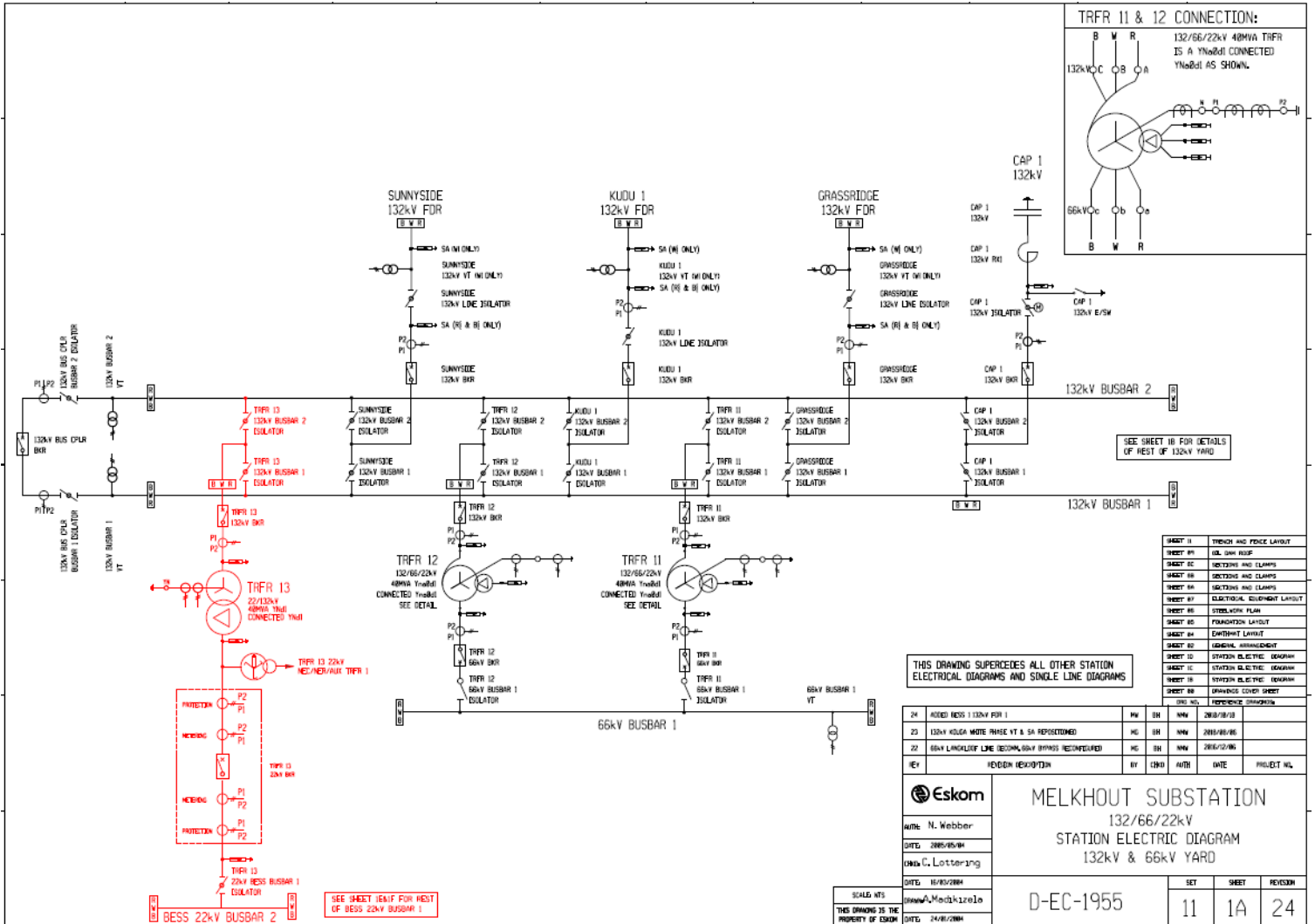

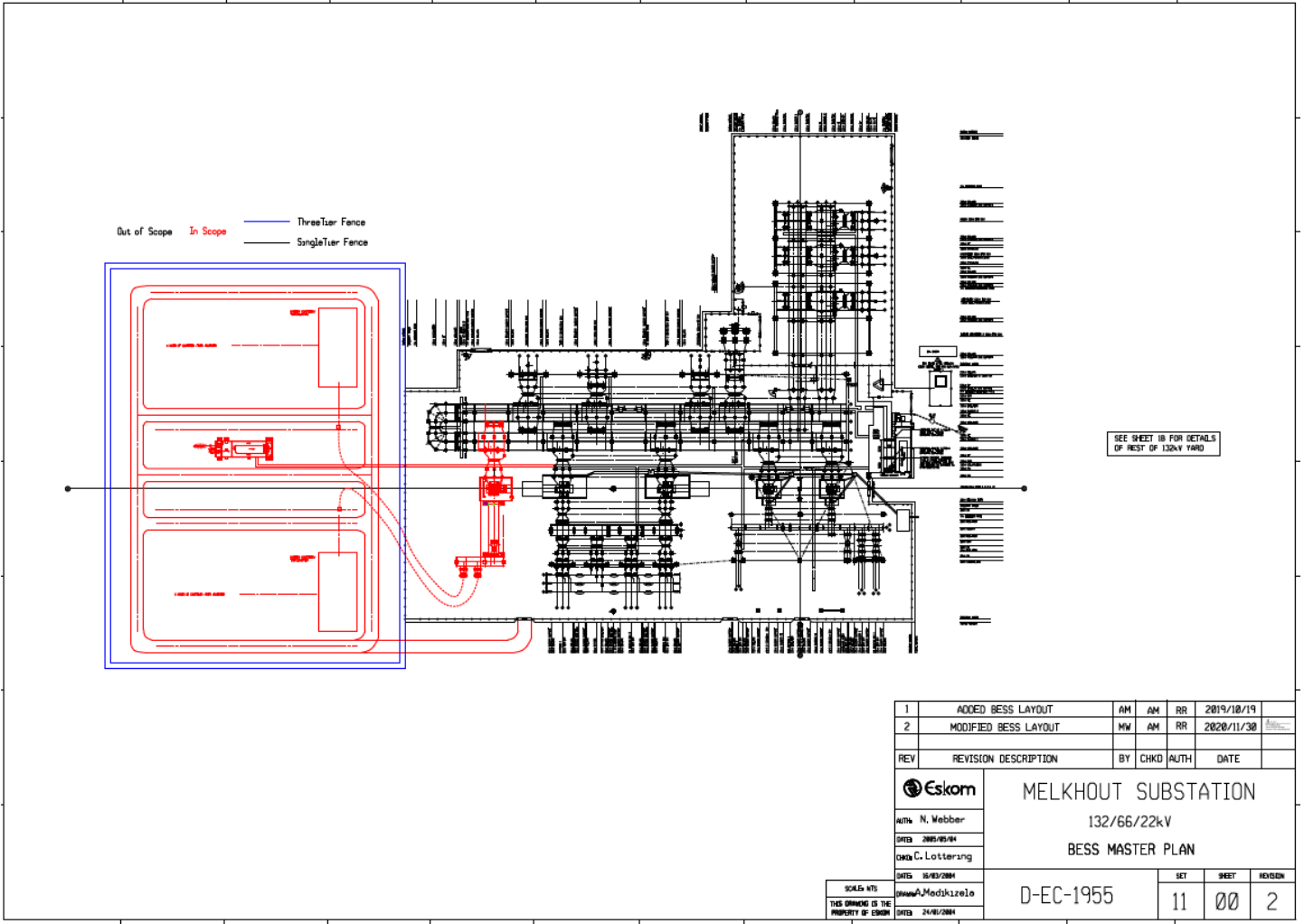

**Appendix 3**                    **Feasibility Study Report**

**Appendix 4 – Determination award by the DMRE**

- *Both appendices are too large to be attached to the application and will be submitted as part of a Large File Transfer*