**Conversion of the Ankerlig Power Station
Open Cycle Gas Turbine Units
to
Combined Cycle Units**

Noise Modelling & Impact Assessment

PREPARED BY:

Demos Dracoulides



CAPE TOWN

PO Box 60034, 7439 Table View, Cape

Tel: 021 556 3837 • Fax: 021 557 1078

Email: DemosD@xsinet.co.za

JOHANNESBURG

PO Box 1668, Northriding 2162

Tel:011 679 2342 • Fax:011 679 2342

SUBMITTED TO:

Savannah Environmental (Pty) Ltd

September 2008

Report No:ATNIA-220908

Table of Contents	page
<i>GLOSSARY OF TERMS</i>	iii
<i>1 INTRODUCTION</i>	1
1.1 Terms of Reference	1
1.2 Study Area	2
<i>2 STUDY APPROACH AND ASSESSMENT METHODOLOGY</i>	3
2.1 Noise Measurements	3
2.2 Noise Modelling	6
2.2.1 Noise Emission Sources	7
2.2.2 Main Noise Modelling Assumptions and Modelling Scenarios	8
2.3 Noise Guidelines and Noise Control Regulations	10
2.4 Noise Impact Assessment of Significance – Method	12
<i>3 AMBIENT NOISE MEASUREMENTS AND PREDICTED NOISE LEVELS</i>	<i>14</i>
3.1 Measured Ambient Noise Levels	14
3.2 Predicted Noise Levels	15
3.2.1 Noise Levels at Discrete Receptors	16
<i>4 IMPACT ASSESSMENT AND RECOMMENDATIONS</i>	<i>21</i>
4.1 Noise Impact Rating	21
4.2 Conclusions	22
4.3 Recommendations	23
4.4 Noise Management Measures	24
<i>REFERENCES</i>	<i>26</i>
<i>APPENDIX A</i>	<i>26</i>
❖ Noise Monitoring Locations	26
<i>APPENDIX B</i>	<i>32</i>
Noise Model Sound Power Input Data	32
<i>APPENDIX C</i>	<i>45</i>
<i>APPENDIX D</i>	<i>46</i>
Graphical Results from Noise Modelling	46
<i>APPENDIX E</i>	<i>62</i>
Noise Emission Sources from Siemens and B&V	62
<i>APPENDIX F</i>	<i>67</i>

List of Tables	page
Table 2.1: Sound Level Measurement Instrumentation	5
Table 2.2: WHO Guidelines for Ambient Sound Levels	10
Table 2.3: Typical Rating Levels for Ambient Noise	11
Table 2.4: Categories of Community/Group Response	12
Table 2.5: Noise Impact Magnitude Assessment Criteria	12
Table 2.6: Noise Impact Ranking Scales	13
Table 2.7: Environmental Significance Rating	13
Table 3.1: Measured Noise Levels.....	14
Table 4-1. Construction: Noise Impact Assessment Ranking and Environmental Significance	21

Table 4-2. Operation: Noise Impact Assessment Ranking and Environmental Significance	21
Table B-1. Open Cycle and Combined Cycle Equipment Sound Power Emission Levels	32

List of Figures	page
Figure 1-1. Locality Map	2
Figure 2-1. Site Layout	3
Figure 2-2. Locations of the Ambient Noise Monitoring Points	5
Figure 2-3. Ankerlig Power Station Noise Sources	8
Figure 2-4. Three-Dimensional Representation of the Ankerlig Power Station.....	9
Figure 3-1. Locations of Discrete Receptors.	17
Figure 3-2. Discrete Receptor Results for the Atlantis Residential Area	18
Figure 3-3. Noise Modelling Results at Boundary of Power Station (Day-time).....	19
Figure 3-4. Noise Modelling Results at Boundary of Power Station (Night-time)	20

GLOSSARY OF TERMS

Acoustics: The science of sound.

Ambient Noise: The distinctive acoustical characteristics of a given area consisting of all noise sources audible at that location. In many cases, the term ambient is used to describe an existing or pre-project condition.

Attenuation: The reduction of noise.

A-Weighting: A method used to alter the sensitivity of a sound level meter with respect to frequency, so that the instrument is less sensitive at frequencies where the human ear is less sensitive. Also written as dBA.

Decibel or dB: Fundamental unit of sound, defined as ten times the logarithm of the ratio of the sound pressure squared over the reference pressure squared.

Frequency: The measure of the rapidity of alterations of a periodic acoustic signal, expressed in cycles per second or Hertz.

Hard Ground: An acoustically reflecting surface, such as concrete, most other paving materials and water. Contrasts with 'soft ground'.

L_{eq}: Equivalent or energy-averaged sound level.

Noise Contour: Lines plotted on maps or drawings connecting points of equal sound levels.

Noise: Unwanted sound.

Noise-sensitive receptor: Location where noise can interrupt ongoing activities and can result in community annoyance, especially in residential areas. These areas may include schools, libraries, hospitals, residences, retirement communities and nursing homes as examples of noise-sensitive receptors.

Receiver/Receptor: A stationary far-field position at which noise levels are specified via measurement or calculated via a noise model.

Soft Ground: Acoustically absorbent surface, such as grass, or tilled earth, which attenuates sound propagating over it, notably for points near the ground. See also 'hard ground'.

Sound Power: The total sound energy radiated by a source per second.

Sound Pressure Level: The amplitude of the changes in pressure level of a sound wave, measured in either pressure units (Pa) or using the decibel logarithmic reference scale.

Study Area: Refers to the entire study area as indicated on the study area map.

1 INTRODUCTION

Savannah Environmental (Pty) Ltd has appointed DDA in order to provide input regarding air pollution and noise for the Environmental Impact Assessment (EIA) phase of the conversion of the Atlantis Power Station Open Cycle Gas Turbine (OCGT) units to Combined Cycle Gas Turbine (CCGT) units.

The Ankerlig Power Station upgrade project entails the conversion of the 9 open cycle gas turbine (OCGT) units (4 existing units and 5 that are currently under construction) to combined cycle gas turbine (CCGT) units. The noise associated with construction activities and the operation of Combined Cycle Gas Turbine units, which could have impact on the surrounding areas to the power station and the Atlantis communities, is assessed in this report.

1.1 Terms of Reference

The main aims of the noise study are to estimate the overall noise increase or reduction due to the conversion and determine the contribution of the operational noise emissions to the current noise levels in the area. Secondly, to assess compliance with guidelines along the boundaries, as well as in the surrounding community. Therefore, the study will cover the:

- Establishment of existing noise levels around the power station site.
- Identification of all potential noise-sensitive receptors that could be impacted upon by activities relating to operation of the proposed development.
- Estimation of resulting noise levels due to the conversion.
- The assessment of the impacts based on comparisons of the resulting noise levels against the pre-operation ambient conditions, as well as against relevant standards and guidelines. The cumulative effect of existing noise levels will be taken into consideration in the impact assessment.
- Provision of recommendations regarding the noise monitoring positions and the establishment of a noise-monitoring programme.
 - Development of a 3-dimensional noise model that represents the various scenarios.
 - Noise modelling of the noise levels within and around the proposed development site.
 - Assessment of the noise impact at identified noise-sensitive receptors, in terms of SANS 10328 and the South African Noise Control Regulations.
 - Recommendations regarding noise mitigation procedures and measures, if proven to be necessary.

1.2 Study Area

The Ankerlig Power Station is situated on the western side of the Atlantis Industrial Zone (see Figure 1-1). This area is located 7 km inland from the Cape West Coast, approximately 40 km north of Cape Town. The existing Ankerlig Power Station is approximately 10 km northeast of Eskom's Koeberg Nuclear Power Station.

Potentially sensitive receptors within the study area include:

- The residential township of Atlantis;
- The informal settlement of Witzand;
- Open farmlands around the power station site.



Figure 1-1. Locality Map

2 STUDY APPROACH AND ASSESSMENT METHODOLOGY

The study approach incorporated ambient noise measurements around the site during daytime and night-time, noise modelling of the nine open cycle units in operation, noise modelling of the combined cycle units, as well as the modelling of the proposed cumulative effect of the Acacia units' relocation to Ankerlig. Figure 2-1 below shows the location of the open cycle gas turbines (OCGT), the combined cycle units and the Acacia relocation position.

The noise modelling calculations for the various phases of the proposed plant were utilised for the determination of the resulting noise levels and the impact assessment in the surrounding areas.

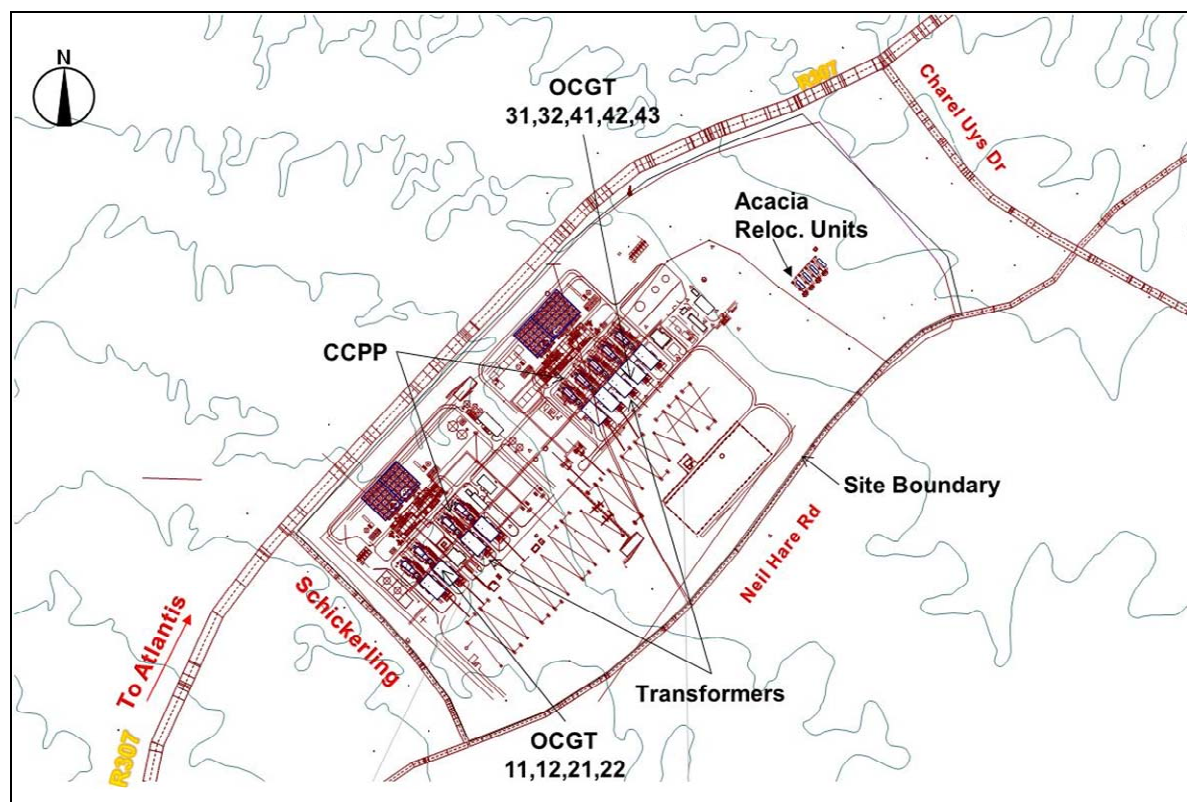

Figure 2-1. Site Layout

2.1 Noise Measurements

Noise measurements were performed for the establishment of the noise levels around the Atlantis Power Station, as well as at the closest noise-sensitive receptor to the site, i.e. Avondale. The ambient measurements were performed intermittently over two days, i.e. the 8th and 9th of April, which covered the daytime as well as night-time periods.

Three noise monitoring locations were selected. The first was positioned on the northern border of the site, the second within the Atlantis community, in the closest position to the

power station, and the third on the western side of the site, towards the West Coast Biosphere Reserve. These locations are indicated as monitoring points MP1, MP2 and MP3 in Figure 2-2 below.

The measurement location was chosen for the following reasons:

- Easily definable and with easy future access in case of need for comparison measurements during construction and after completion of the project.
- Relevant to the concerns of potentially affected parties.

Details of the monitoring positions, the noise measurement datasheets and photographs of the locations can be found in APPENDIX A.

All measurements were carried out in accordance with:

- the SOUTH AFRICAN NATIONAL STANDARD - Code of Practice, SANS 10103:2008, The measurement and rating of environmental noise with respect to land use, health, annoyance and to speech communication;
- the regulations of the DEPARTMENT OF ENVIRONMENTAL AFFAIRS AND TOURISM. NO. R. 154. Noise Control Regulations in Terms of Section 25 of the Environmental Conservation Act, 1989 (Act No. 73 of 1989). Govt. Gaz. No. 13717, 10 January 1992.



Figure 2-2. Locations of the Ambient Noise Monitoring Points

The measurements were performed with a 01dB, Type 1, Data-logging Precision Impulse Integrating Sound Level Meter SIP95 (see Table 2.1). The Sound Level Meter was calibrated before and after each measurement session with a 01dB Calibrator CAL21, Type 1, 94dB, 1 kHz. The above-mentioned equipment, i.e. sound level meter and calibrator, have valid calibration certificates from the testing laboratories of De Beer Calibration Services and comply with the following international standards:

- IEC 651 & 804 – Integrating sound level meters.
- IEC 942 – Sound calibrators.

Table 2.1: Sound Level Measurement Instrumentation

Instrument	Type	Serial No
1. Precision Integrating Sound Level Meter	01dB SIP 95	10741
1a. Microphone	01dB MK 250	3857
1b. 1/3 rd Octave Band Filter	01dB Real Time Digital Filter	10741
2. Field Calibrator	01bB CAL 01 S	40182

The continuous A-weighted equivalent sound pressure levels (L_{Aeq}) of at least a 10-minute duration were taken. Abnormal disturbances, such as loud noise generation in close proximity or sudden noise bursts that affect the measurement, were discarded. In addition, the occurring maximum (L_{max}) and minimum levels (L_{min}) during the measurement period, as well as the L_{90} were also recorded.

All the noise measurements were performed in compliance with the weather condition requirements as specified by the SANS Codes. Therefore, measurements were not performed in the presence of fog, rain, wind with a steady speed exceeding 5 ms^{-1} or wind with gusts exceeding 10 ms^{-1} . The wind speed was monitored at each location with a portable meter capable of measuring the wind in meters per second. Additional meteorological parameters, such as temperature, humidity and barometric pressure were also recorded.

2.2 Noise Modelling

The noise modelling approach included estimations of the noise levels within and around the site for all the stages of the proposed development. In addition, noise levels were estimated at several discrete receptors, positioned around the site boundaries and noise-sensitive locations. These estimations were performed via the internationally accepted prediction software package CadnaA (Computer Aided Noise Abatement). The latter was selected for the following specific reasons:

- It provides an integrated environment for noise predictions under varying scenarios of operation.
- The cumulative effects of various sources can be estimated in a three-dimensional environment.
- The ground elevations around the entire site can be entered into the model, and their screening effects can be taken into consideration.
- The noise propagation influences of the meteorological parameters of a specific area can also be accounted for.
- It provides noise barrier optimisation in terms of location, height, type and absorbent material coverage.

CadnaA has been utilised in many countries in the European Union (EU) and the USA for the modelling of environmental noise and town planning. It is comprehensive software for 3-dimensional calculations, presentation, assessment and prediction of environmental noise, covering noise emissions of industrial plants, parking lots, roads, railway schemes or entire towns and urbanized areas.

The CadnaA currently incorporates more than 30 international implemented standards and guidelines. The selected standards to be utilised in the Apollo Brick noise modelling study are the recommended computational methods in the EC Directive on Environmental Noise 2002/49/EC for noise emission and noise propagation estimations.

2.2.1 Noise Emission Sources

The conversion of the Ankerlig Power Station units from open cycle to combined cycle gas turbine will introduce additional noise sources, since the gases will have to pass through a new Heat Recovery Steam Generator (HRSG) system after the gas turbines. This process will increase the efficiency of the power station.

The main noise sources during construction and operation have been identified as:

- The construction equipment and activities during the construction phase.
- The equipment during the operational phase such as (refer to Figure 2-3):
 - the open cycle gas turbines (OCGTs);
 - the generators;
 - the air filters;
 - the gas turbine fan coolers;
 - the electricity transformers;
 - the stacks;
 - the heat recovery steam generators (HRSGs);
 - the steam turbine generators (STGs);
 - the closed cycle cooling water coolers (CCCWCs)
 - low and high pressure pumps;
 - the air-cooled condensers (ACCs).

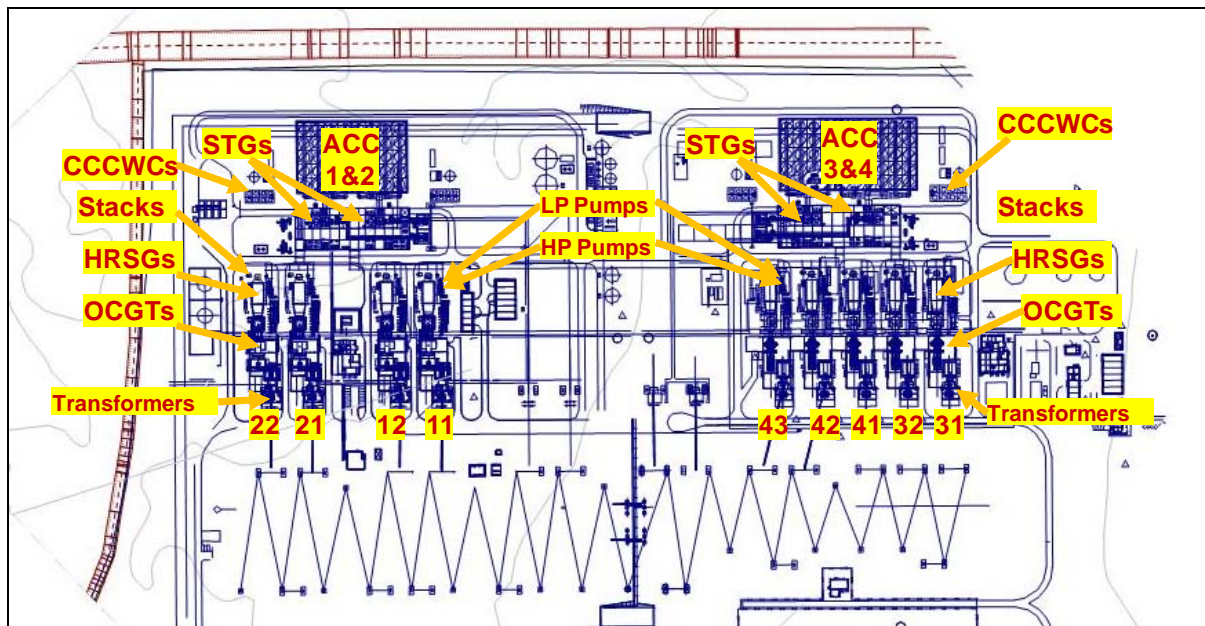

Figure 2-3. Ankerlig Power Station Noise Sources

The sound power of the nine open cycle equipment was obtained from the Siemens report W7P/2005/031. The tables with the sound power from this report are included in APPENDIX E.

The sound power of the proposed combined cycle equipment was provided by the design engineers Black & Veatch (B&V). The sound emission information tables are provided also in APPENDIX D.

Some of the combined cycle power plant equipment, such as the heat recovery steam generators, boilers, etc. will be placed within appropriately designed noise enclosures, in order to reduce the noise emissions to the environment and ensure compliance with relevant legislation and guidelines. Two additional mitigation options have been indicated by B&V as “Intermediate” and “Substantial”. Both of these mitigation options, in addition to the main option, were included in the model setup and the noise modelling calculations. Details of the proposed B&V mitigation measures can be found in APPENDIX E.

The noise source from the potential relocation of the Acacia Poser Station units were also included in the modelling for the assessment of cumulative impact. The sound power of these units were determined via measurements at the station and can also be seen in APPENDIX D.

2.2.2 Main Noise Modelling Assumptions and Modelling Scenarios

The main assumptions utilised in the modelling were:

- For the noise propagation, the ground was considered partially noise-reflective.

- No mitigation measures in place, other than the existing ones applied to the open cycle units and the primary measures to the combined cycle units.
- Wind speed and direction favourable to the receivers.
- Daytime temperature and humidity 25°C and 60% respectively.
- Night-time temperature and humidity 12°C and 80% respectively.

The ground elevations and the screening of noise due to buildings were taken into consideration in the modelling. The existing and proposed plant layout were digitised and introduced into the model. An example of the resulting three-dimensional representation of the proposed development in the CadnaA model is shown in the following Figure 2-4.

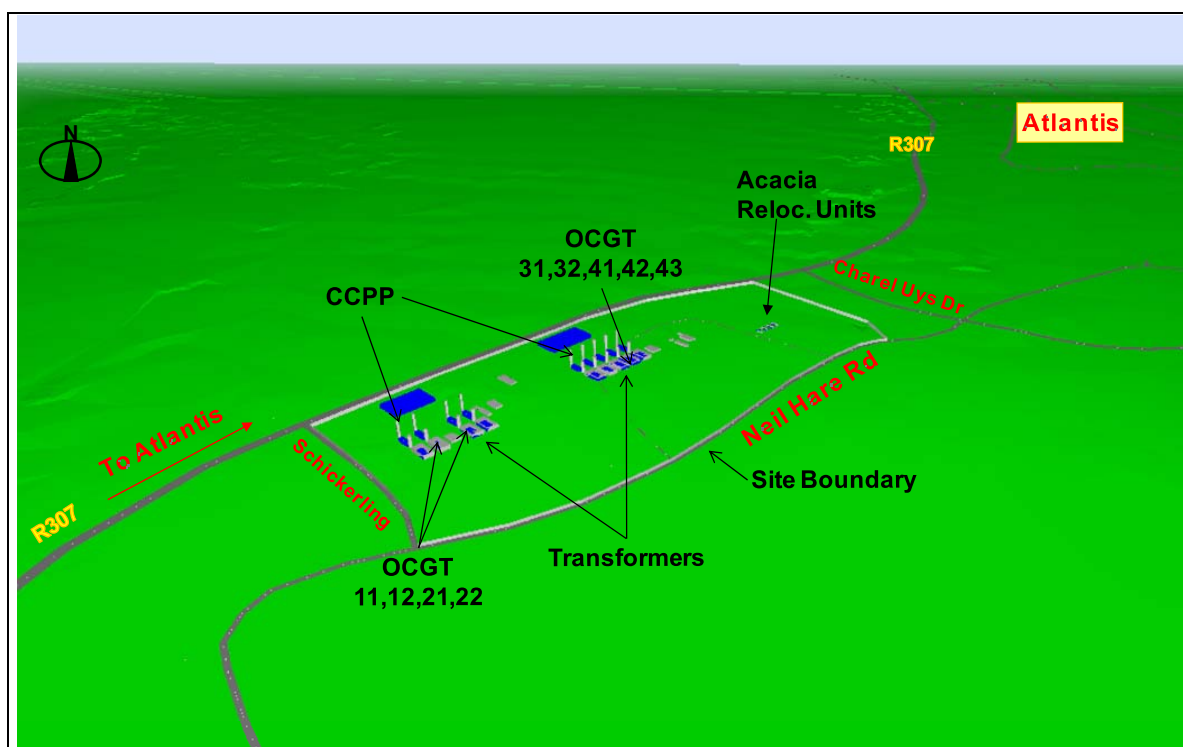

Figure 2-4. Three-Dimensional Representation of the Ankerlig Power Station

For comparison purposes the future noise levels around the site were estimated for the following 8 scenarios, which included the cumulative impact of the Acacia Power Station relocation:

Scenario 1: Existing Situation: Open Cycle Gas Turbine units (9 units)

Scenario 2: Combined Cycle units (9 units)

Scenario 3: Combined Cycle units + Intermediate mitigation measures

Scenario 4: Combined Cycle units + Substantial mitigation measures

Scenario 5: Open Cycle Gas Turbine units (9 units) + Acacia units

Scenario 6: Combined Cycle units + Intermediate mitigation measures + Acacia units

Scenario 7: Combined Cycle units + Substantial mitigation measures+ Acacia units

Scenario 8: Acacia Power Station only

The modelling results are presented and discussed in Section 3.2 further below.

2.3 Noise Guidelines and Noise Control Regulations

Internationally, the standards applied by different countries are generally similar. The current trends are to apply more stringent criteria due to the deteriorating noise climate.

The World Health Organisation (WHO) has developed its own assessments on the effects of the exposure to environmental noise. Based on these assessments, several guideline values for different time periods and situations have been specified.

The WHO has recommended that a standard guideline value for average outdoor noise levels of 55 dBA be applied during daytime, in order to prevent significant interference with the normal activities of local communities. The relevant night-time noise level is 45 dBA. The WHO further recommends that, during the night, the maximum level of any single event should not exceed 60 dBA. This limit is to protect against sleep disruption. In addition, ambient noise levels have been specified for various environments. These are presented in the following Table 2.2.

Table 2.2: WHO Guidelines for Ambient Sound Levels

Environments	Ambient Sound Level L_{Aeq} (dBA)			
	Daytime		Night-time	
	Indoor	Outdoor	Indoor	Outdoor
Dwellings	50	55	-	-
Bedrooms	-	-	30	45
Schools	35	55	-	-

The noise impact on the areas surrounding the site was determined in terms of the difference between the existing measured or typical noise levels in that area and the predicted levels for the proposed development activities.

This difference was assessed in accordance with the guidelines provided in the SANS Code of Practice 10103:2008 'The measurement and rating of environmental noise with respect to annoyance and to speech communication', as well as the noise regulations applicable to the Western Cape: Noise Control Regulations (Section 25), Environmental Conservation Act 73 of 1989 (DEAT, 1998). The latter regulations define noise as 'disturbing' if it

causes the ambient noise level to increase by 7 dBA or more over the existing ambient level of the area.

The typical rating levels, $L_{Req,T}$, of noise within each of the area surrounding the proposed development site were measured or selected in accordance with the following Table 2.3 from the SANS 10103 Code.

Table 2.3: Typical Rating Levels for Ambient Noise

Type of District	Outdoors Rating Level $L_{Req,T}^{1,2}$ (dBA)	
	Day-time	Night-time
Rural districts	45	35
Suburban districts with little road traffic	50	40
Urban districts	55	45
Urban districts with workshops, business premises and main roads	60	50
Central business districts	65	55
Industrial districts	70	60
¹ A-weighted equivalent continuous rating levels, which include corrections for total character and impulsiveness of the noise. ² Day-time: 06:00 – 22:00, Night-time: 22:00 – 06:00		

Human perception of the change in sound is subjective and does not bear a close relation to actual change, for example:

- A change in noise level of 3 dBA is just detectable;
- A change in noise level of 5-6 dBA is clearly perceptible; and
- A change in noise level of 10 dBA is perceived roughly as doubling or halving of loudness.

SANS 10103 provides a guideline for predicting a community response to the increase in the ambient noise levels. The expected response of the local community to the noise impact, i.e. the increase of noise over the current ambient, is primarily based on Table 5 of SANS 10103, but expressed in terms of the effects of impact on a scale of ‘very low’ to ‘very high’ (see Table 2.4 and Table 2.5). The assessment of the noise impact magnitude or severity of the noise increase in the affected areas was based on the $L_{Req,T}$ excess ($\Delta L_{Req,T}$) according to Table 2.5.

Table 2.4: Categories of Community/Group Response

Excess of $L_{Req,T}$ ¹ (dBA)	Estimated Response	
	Response Category	Description
0	None	No observed reaction
$0 < \Delta L_r \leq 3$	None to Little	Change slightly noticeable
$0 < \Delta L_r \leq 10$	Little	Sporadic complaints
$5 < \Delta L_r \leq 15$	Medium	Widespread complaints
$10 < \Delta L_r \leq 20$	Strong	Threats of community/group action
¹ Expected increase of ambient noise in an area due to a proposed development		

Table 2.5: Noise Impact Magnitude Assessment Criteria

Increase in $L_{Req,T}$ (dBA)	Impact
$\Delta L_r \leq 3$	Very low
$3 < \Delta L_r \leq 5$	Low
$5 < \Delta L_r \leq 10$	Medium
$10 < \Delta L_r \leq 15$	High
$15 < \Delta L_r$	Very High

The impact assessment in the noise study was conducted in accordance with the above-mentioned regulated permissible noise level increase of 7 dBA.

Two additional factors were taken into consideration for the noise impact assessment, in accordance with the SANS 10103 Code:

- The rural district guideline, and;
- The expected community reaction due to an existing noise level increase.

In order to establish a uniform approach regarding the assessment of impacts, Savannah has issued a procedure in terms of rating values for the determination of the overall noise impact due to the project. In accordance with this procedure, several aspects of the impact, such as the extent, duration, intensity and probability are to be taken into account. The detailed description of the methodology is provided in the following section.

2.4 Noise Impact Assessment of Significance – Method

The significance of potential environmental impacts identified will be determined using the following approach, taking into consideration the following aspects:

a) Probability of occurrence

b) Duration of occurrence

a) Magnitude of impact

b) Scale/extent of impact

In order to assess each of these factors for each impact, ranking scales were employed as follows:

Table 2.6: Noise Impact Ranking Scales

Probability:	Duration:
5 – Definite	5 - Permanent
4 - Highly probable	4 - Long-term (> 15 years)
3 – Probable	3 - Medium-term (5-15 years)
2 - Improbable	2 - Short-term (2-5 years)
1 - Very improbable	1 - Immediate (0 -1 years)
Extent:	Magnitude:
5 - International	10 - Very high
4 - National	8 – High
3 - Regional	6 - Moderate
2 - Local	4 - Low
1 - Site only	2 - Minor
	0 - None

Once the above factors had been ranked for each impact, the overall risk (environmental significance) of each impact will be assessed using the following formula:

$$S = (scale + duration + magnitude) \times probability$$

The maximum value is 100 significance points (S). Environmental impacts will be rated as either of **High**, **Moderate** or **Low** significance on the following basis:

Table 2.7: Environmental Significance Rating

Environmental Significance	Significance Points
High	SP > 60
Moderate	30 ≤ SP ≤ 60
Low	SP < 30

The impact assessment will also include:

- The **nature**, a description of what causes the effect, what will be affected and how it will be affected.
- The **status**, which is described as either positive, negative or neutral.
- The degree to which the impact can be reversed.
- The degree to which the impact may cause irreplaceable loss of resources.
- The degree to which the impact can be mitigated.

3 AMBIENT NOISE MEASUREMENTS AND PREDICTED NOISE LEVELS

The current noise levels in the vicinity of the Ankerlig Power Station were measured, and the resulting noise levels from the operational phase of the proposed development were calculated for the various scenarios, utilising the methodology outlined in Section 2.

The noise measurements and future resulting noise levels are presented and discussed in the following sections.

3.1 Measured Ambient Noise Levels

Table 3.1 below shows the averaged values of the noise measurements at the three selected locations for representative daytime and night-time periods. The detailed measurement parameters can be found in APPENDIX A.

Table 3.1: Measured Noise Levels

Monitoring Point	Daytime	Night-time	District	SANS Guideline (dBA)	
	(dBA)	(dBA)		Daytime	Night-time
North-eastern side of site (MP1)	49.9	52.7	Industrial	70	60
Atlantis residential area (MP2)	48.8	48.3	Suburban	50	40
Western side of site (MP3)	53.9	50.6	Rural	45	35

During the measurements at positions MP1 and MP3, the main noise sources were:

- The earth moving and construction equipment.
- The adjacent industrial plant, north of the Ankerlig site.
- Vehicular traffic on the R307.

At the southern border of the Atlantis community (i.e. position MP2), the primary noise sources were:

- Human activities.
- Vehicular traffic on the local road network.
- Natural sounds.
- General industrial sound in the distance.

From Table 3.1, it can be seen that the average measured noise level on the north-eastern side of the plant, towards Atlantis and the existing industrial area, was 50 dBA and 53 dBA during daytime and night-time respectively. Both noise levels fall within the SANS daytime and night-time guidelines for industrial areas of 70 dBA and 60 dBA respectively.

The noise level on the southern border of the Atlantis residential area was 49 dBA during the daytime and 48 during night-time. The daytime level was within the 50 dBA SANS guideline for a suburban area. The night-time, however, exceeded the 40 dBA guideline.

The noise levels on the western side of the Ankerlig site, beyond the R307, were 54 dBA during daytime and 51 dBA during night-time. They are both in excess of the rural SANS guidelines of 45 dBA and 35 dBA for daytime and night-time respectively. This, however, was to be expected due to the existing vehicular traffic on the R307 and the current construction activities at the Ankerlig site.

3.2 Predicted Noise Levels

Based on the noise modelling methodology and input data outlined in Section 2, the noise contours around the site were estimated for the following 8 scenarios including Acacia Power Station relocation:

Scenario 1: Existing Situation: Open Cycle Gas Turbine units (9 units)

Scenario 2: Combined Cycle units (9 units)

Scenario 3: Combined Cycle units + Intermediate mitigation measures

Scenario 4: Combined Cycle units + Substantial mitigation measures

Scenario 5: Open Cycle Gas Turbine units (9 units) + Acacia units

Scenario 6: Combined Cycle units + Intermediate mitigation measures + Acacia units

Scenario 7: Combined Cycle units + Substantial mitigation measures+ Acacia units

Scenario 8: Acacia Power Station only (used for the cumulative impact)

The noise contours for daytime and night-time conditions for each of the above-mentioned scenarios can be seen in APPENDIX D.

From Figure D-1-a and Figure D-1-b for the open cycle units, it can be seen that the 40 dBA noise contour reached Avondale. The 60 dBA noise contour was contained within the Ankerlig site boundaries.

For the open and combined cycle units the 40 dBA extended to Protea Park, with the 50 dBA almost reaching Avondale. The 60 dBA noise contour extended approximately 600m from the western and south-western boundaries but was contained within the eastern and north-western boundaries (refer to Figure D-2-a and Figure D-2-b).

The introduction of the Intermediate and Substantial mitigation measures will reduce the noise levels around the site for the combined cycle units. As can be seen from Figure D-4-a and Figure D-4-b, the substantial mitigation measures will result in noise levels similar to the open cycle units.

The cumulative noise levels of the open cycle units, together with the Acacia units relocated to Ankerlig, can be seen in Figure D-5-b and Figure D-6-a for daytime and night-time respectively. The Acacia units will have an effect on the noise levels along the north-eastern boundary of the site. This impact, however, will not reach beyond the site's boundaries and will have no effect on the Atlantis noise-sensitive receptors. The noise levels from the Acacia units only were also produced for reference purposes (Figure D-8-a and Figure D-8-b). It can be seen that the 55 dBA noise contour was contained within the Ankerlig site boundaries.

Similar results were generated for the cumulative impacts of Acacia with the open and combined cycle units (refer to Figure D-6-b to Figure D-7-b). The worst-case scenario for the relocation with the combined cycle units would be with the Substantial mitigation measures in place. As anticipated, the Acacia relocation for this scenario also did not generate any significant impact changes (refer to Figure D-7-a and Figure D-7-b).

3.2.1 Noise Levels at Discrete Receptors

In addition to the noise contour maps, the noise levels were calculated at several discrete receptors around the Ankerlig site. These were positioned along the site's boundaries, at the noise monitoring positions (MP1, MP2 and MP3), as depicted in Figure 3-1 below.

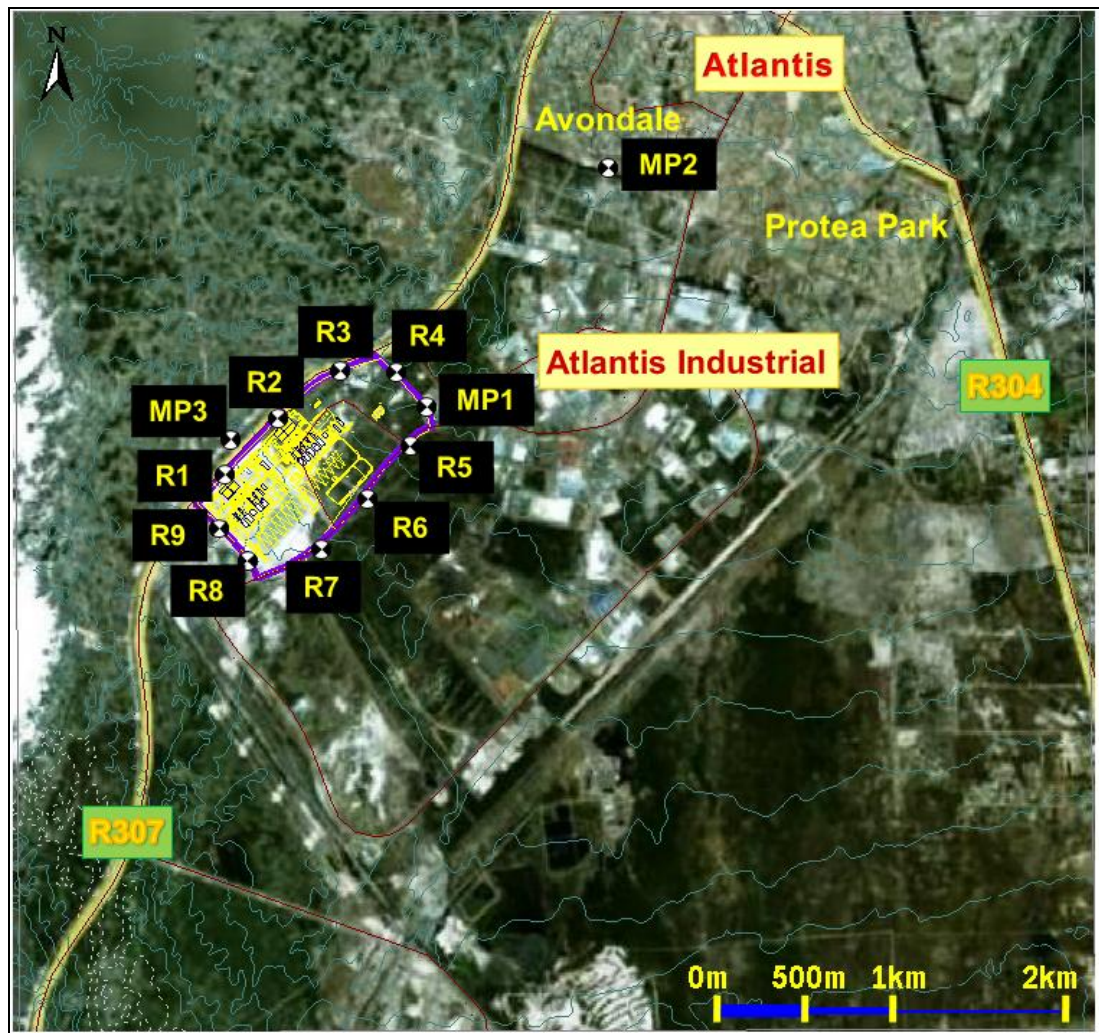

Figure 3-1. Locations of Discrete Receptors.

Figure 3-2 below depicts the noise contribution of the Ankerlig Power Station for the various scenarios examined for daytime and night-time conditions at the southern border of the Atlantis Residential area. As can be seen, the open cycle units (OC) will contribute between 42 dBA and 42.4 dBA for the daytime and night-time conditions respectively. There will be an increase of approximately 1 dBA in the resulting noise levels of the combined cycle units, with no intermediate or substantial mitigation measures in place.

The introduction of the Acacia units will result in an increase of the noise levels in the Avondale area of approximately 0.2 dBA, which is considered insignificant.

Figure 3-3 and Figure 3-4 show the noise levels along the boundaries of the site, as well as at the MP1 and MP3 locations. The tables with the actual values can be found in APPENDIX C.

It can be seen that the SANS daytime industrial guideline of 70 dBA was exceeded along the north-western and western boundaries of the site for the combined cycle without

additional mitigation measures. The scenario with the substantial mitigation measures generated similar results as the open cycle ones along the site's boundaries.

The night-time SANS guideline of 60 dBA was exceeded at the same locations as those for daytime. The exceedance of this limit, however, was evident for the open cycle as well as the Substantial mitigation option of the combined cycle.

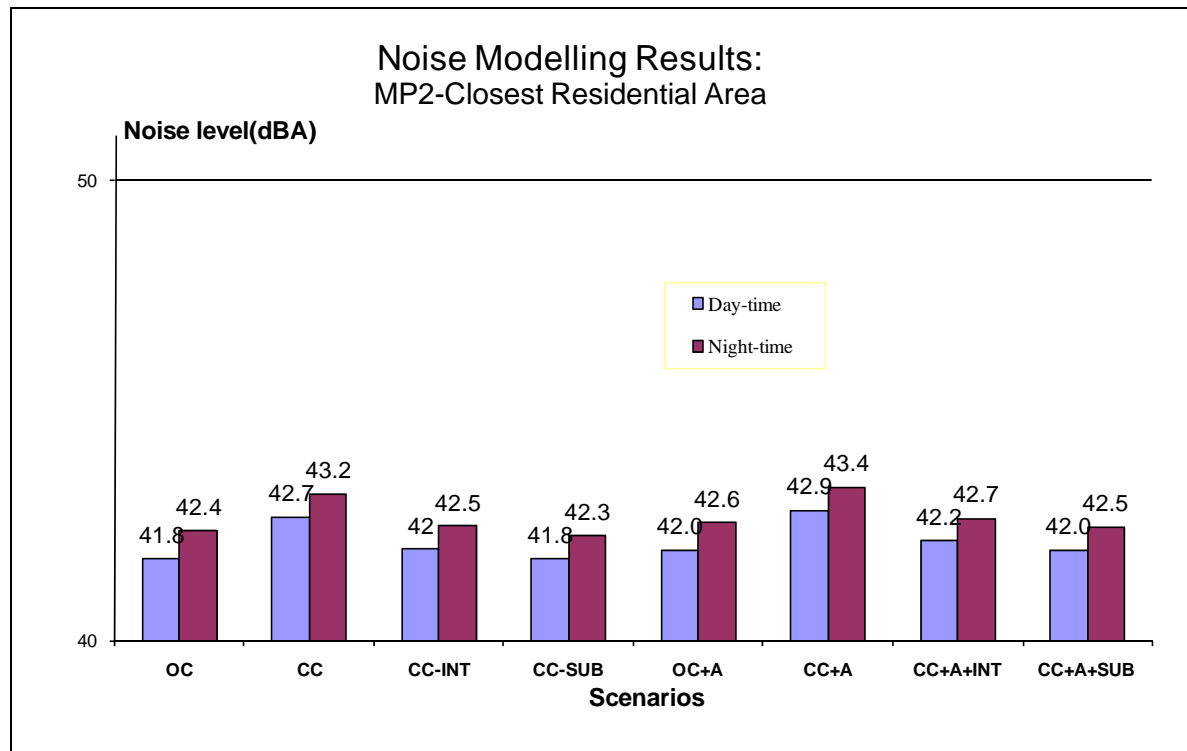

Figure 3-2. Discrete Receptor Results for the Atlantis Residential Area

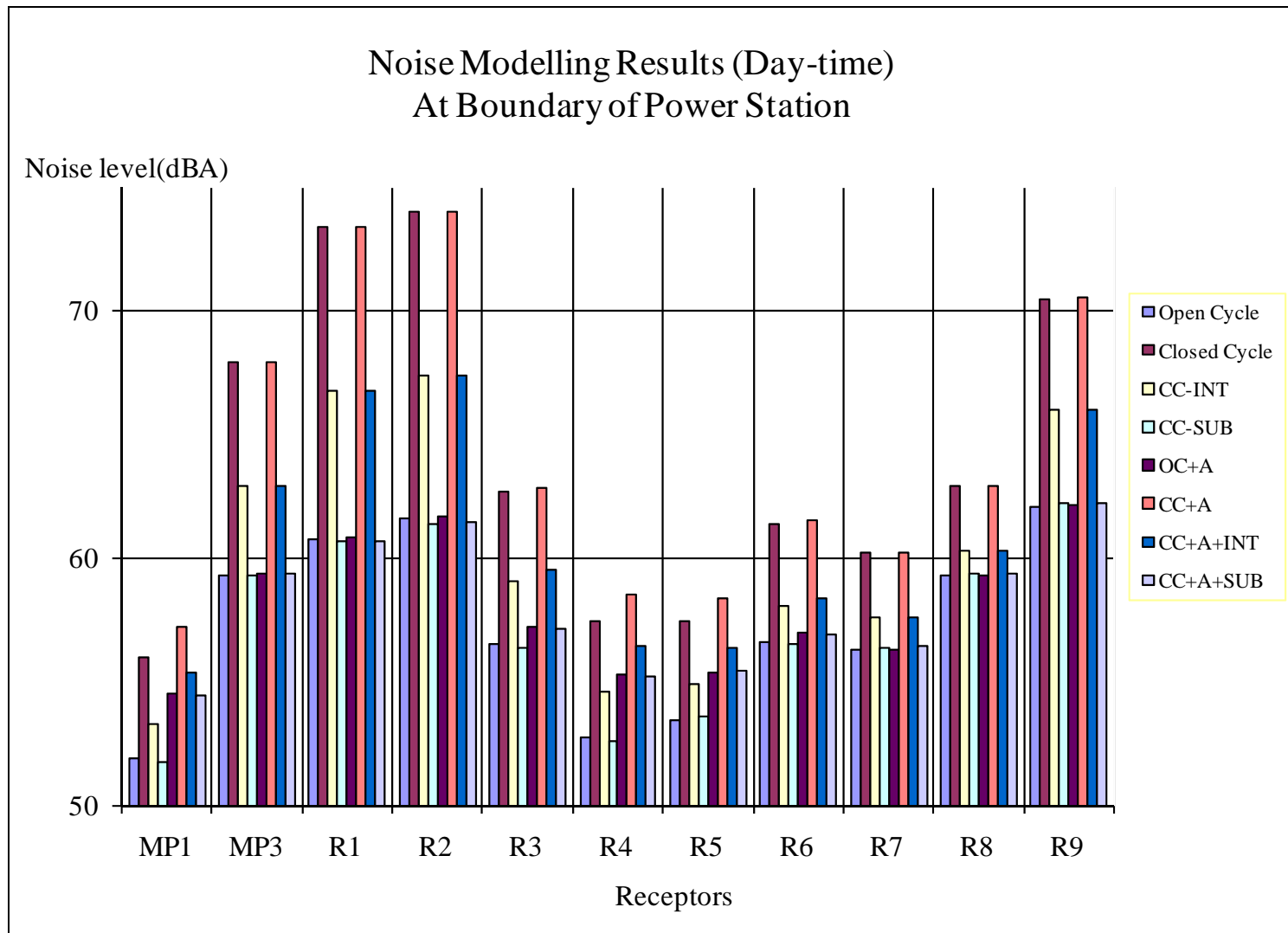

Figure 3-3. Noise Modelling Results at Boundary of Power Station (Day-time)

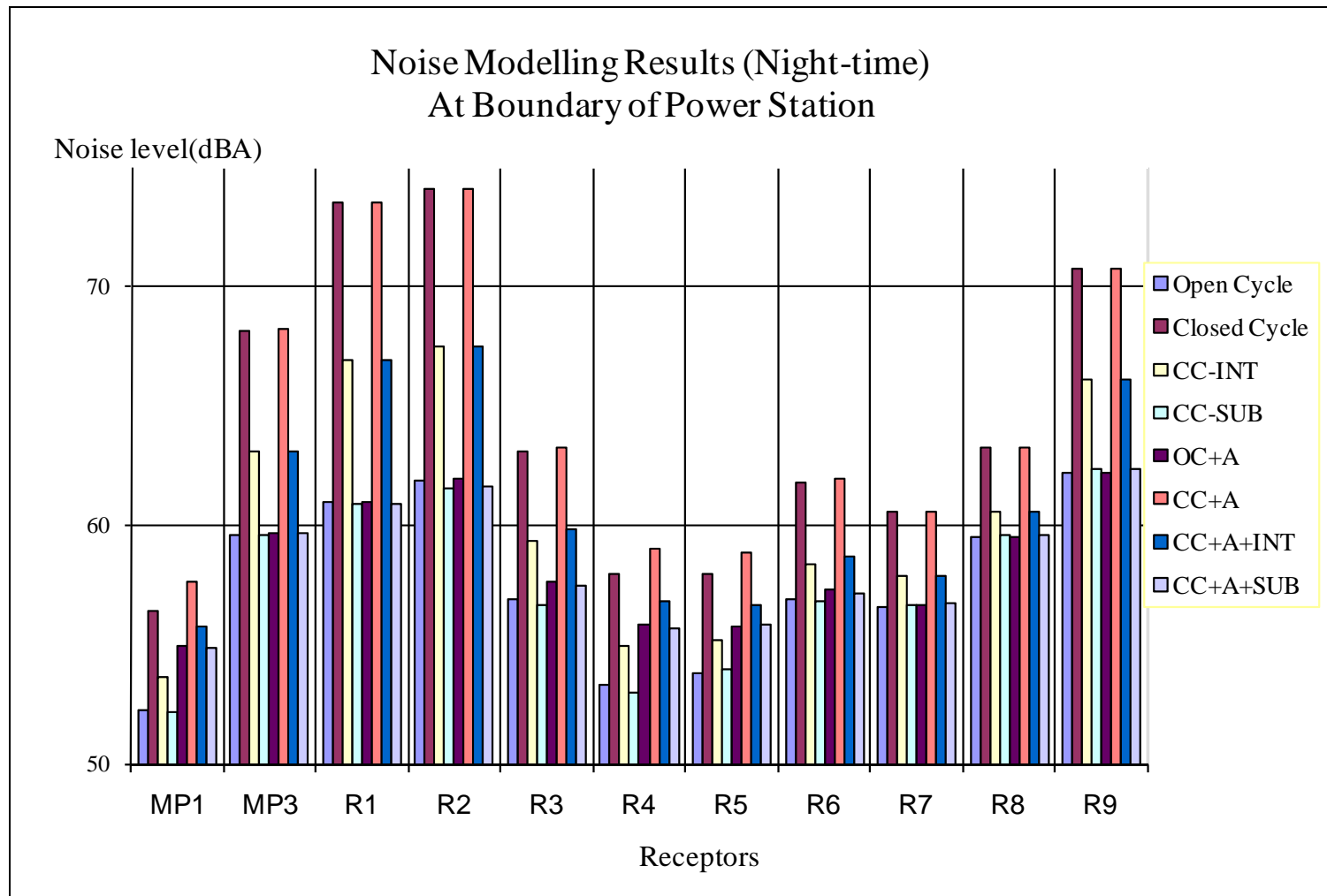

Figure 3-4. Noise Modelling Results at Boundary of Power Station (Night-time)

4 IMPACT ASSESSMENT AND RECOMMENDATIONS

4.1 Noise Impact Rating

Based on the impact ranking described in the impact assessment methodology, the resulting rating and significant points for the Ankerlig Power Station are as follows:

Table 4-1. Construction: Noise Impact Assessment Ranking and Environmental Significance

<i>Nature:</i> Increase of noise levels around the power station construction area.		
	Without mitigation	With mitigation
<i>Extent</i>	Local (2)	Local (2)
<i>Duration</i>	Short-term (2)	Short-term (2)
<i>Magnitude</i>	Low-Moderate (5)	Low (4)
<i>Probability</i>	Probable (3)	Probable (3)
<i>Significance</i>	Low (27)	Low (24)
<i>Status (positive or negative)</i>	Negative	Negative
<i>Reversibility</i>	Reversible	Reversible
<i>Irreplaceable loss of resources?</i>	No loss	No loss
<i>Can impacts be mitigated?</i>	Yes	Yes
<i>Mitigation:</i> Systematic maintenance of equipment and training of personnel to adhere to operational procedures that reduce the occurrence and magnitude of individual noisy events.		
<i>Cumulative impacts:</i> Cumulative impacts due to existing power station units, industrial noise sources in the adjacent Atlantis Industrial area and vehicular traffic in the area.		
<i>Residual Impacts:</i> No residual impact after the activity ceases.		

Table 4-2. Operation: Noise Impact Assessment Ranking and Environmental Significance

<i>Nature:</i> Increase of noise levels around the power station site, in the adjacent rural areas and in Atlantis residential area.			
	Without mitigation	Intermediate Mitigation	Substantial Mitigation
<i>Extent</i>	Local (2)	Local (2)	Local (2)
<i>Duration</i>	Long-term (4)	Long-term (4)	Long-term (4)
<i>Magnitude</i>	High impact (8)	Moderate to high impact (7)	Minor (6)
<i>Probability</i>	Highly probable (4)	Probable (3)	Improbable (2)
<i>Significance</i>	Moderate (56)	Moderate (39)	Low (24)

Status (positive or negative)	Negative	Negative	Negative
Reversibility	Reversible	Reversible	Reversible
Irreplaceable loss of resources?	No irreplaceable loss	No irreplaceable loss	No irreplaceable loss
Can impacts be mitigated?	Yes	Yes	Yes
Mitigation: Intermediate: Increased boiler casing thickness, stack exit silencer, pump upgrades, steam turbine inside enclosure, low noise fans. Substantial: Increased boiler casing thickness, stack exit silencer and transition barrier, place pumps inside enclosure, place steam turbine inside high STC enclosure, low noise fans with inlet and exit silencers and larger footprint.			
Cumulative impacts: Cumulative impacts due to existing industrial noise sources in the adjacent Atlantis Industrial area and vehicular traffic in the area.			
Residual Impacts: No residual impact after the activity ceases.			

4.2 Conclusions

Based on the noise measurements and the noise modelling results, the following can be concluded:

- The existing noise environment around the Ankerlig Power Station has noise levels of around 50 dBA, primarily due to the construction activities currently taking place, the existing industrial sources and the R307.
- The noise levels in the most southern part of the Atlantis residential area, i.e. Avondale and Protea Park, were around 48 dBA during day and night-time. The industrial activity from the Atlantis Industrial area, as well as construction activities were audible but not intrusive.
- In close proximity to the power station, i.e. within 300m from the site boundaries, the operation of the 9 open cycle units will result in an increase of the current (measured) noise levels of around 7 dBA and 10 dBA during daytime and night-time respectively. This increase is considered *Moderate to High*, and it will result in noise levels much greater than the SANS guidelines for rural areas of 45 dBA and 35 dBA during daytime and night-time respectively.
- On introduction of the closed cycle units without additional mitigation measures, the noise levels associated with the nine open cycle units along the site's boundaries will increase between 4 dBA and 13 dBA. This increase is considered *Moderate*.
- The incorporation of the Intermediate mitigation measures will restrict the above-mentioned increase between 3 dBA to 6 dBA.
- The incorporation of the Substantial mitigation measures will eliminate the above-mentioned increase.
- Based on the existing noise levels in the Avondale and Protea Park areas, the expected noise level increase due to the open cycle gas turbines was estimated to be around 1 dBA.

- The introduction of the combined cycle units will increase the current measured noise levels in the Avondale and Protea Park areas by 1 dBA during daytime, and by 1.2 dBA during night time respectively.
- In the Avondale and Protea Park areas, the difference between the noise levels resulting only from the open cycle units and the combined cycle (that includes the open cycle) was found to be 0.5 dBA, which is considered *Negligible*.
- The additional proposed mitigation measures will reduce this noise level increase even further.
- When compared to the open cycle levels and the mitigated combined cycle levels, the relocation of the Acacia electricity generation units will have only a local impact around the north-western boundary, increasing the noise levels by 3 dBA.
- The Acacia units will not have any significant cumulative effect on the noise-sensitive receptors of Atlantis, since the increase above the closed cycle noise levels in the Avondale and Protea Park areas will be below 0.3 dBA.
- The overall noise impact of the combined cycle units without mitigation, taking into consideration the resulting noise levels in the noise-sensitive area of Atlantis, was found to be *Moderate*.
- The introduction of the *Substantial* mitigation measures will reduce the impact rating to *Low*.

4.3 Recommendations

During construction the following is recommended:

- Diesel-powered and other equipment should be maintained regularly and have appropriately fitted silencers.
- Personnel should be specifically trained, in order to adhere to operational procedures that reduce the occurrence and magnitude of individual noisy events.
- Noisy operation such as piling, rock breaking, etc. should be restricted during daytime hours.
- Perimeter noise measurements should be performed biannually. The monitoring to include one or two points within the Atlantis community.

For the operational phase of the combined cycle units, the following is recommended:

- The Substantial mitigation measures should be incorporated, in order to maintain the noise levels around the site similar to the ones expected to be generated by the closed cycle units. These measures include but are not restricted to:
 - Increased boiler casing thickness.

- Introduction of stack exit silencer and transition barrier.
 - Placement of pumps inside enclosure.
 - Placement of steam turbine inside high STC enclosure.
 - Utilisation of low noise fans with inlet and exit silencers and larger footprint.
- Perimeter noise monitoring should be performed annually. For comparison purposes, the measurement points should include the measurement locations utilised in the noise impact assessment.

4.4 Noise Management Measures

OBJECTIVE: The objective is to maintain the noise levels around the power station site within acceptable levels and minimise the impact on residential areas and communities.

Project Component/s	<p>The components affecting the noise impact are the construction activities during the construction phase, and during the operational phase the additional noise sources related to the combined cycle units.</p> <p>The Acacia generation units are also to be relocated on the northern side of the site.</p>
Potential Impact	<p>Increased noise levels in the surrounding areas, noise nuisance and sleep disturbance of the affected communities.</p>
Activity/Risk Source	<p>The activities and equipment which could impact on achieving the objective are:</p> <ul style="list-style-type: none"> • Construction activities, i.e. excavating, loading and unloading of trucks, piling, material transport, general building activities, etc. • Electricity generation units and supporting equipment, such as gas turbines, heat recovery steam generators, stacks, transformers, steam turbine generators, air coolers, pumps, fans, etc.
Mitigation: Target/Objective	<p>The measures required during the construction period are:</p> <ul style="list-style-type: none"> • Regular maintenance of equipment and fitting of silencers where appropriate. • Training of personnel to adhere to operational procedures that reduce the occurrence and magnitude of individual noisy events. • Restricting noisy operation such as piling or rock breaking, etc. to daytime hours. <p>The measures required for the operational phase of the combined cycle units are the ones termed Substantial, i.e.:</p> <ul style="list-style-type: none"> • Increased boiler casing thickness. • Stack exit silencer and transition barrier.

	<ul style="list-style-type: none"> • Pumps inside enclosure. • Steam turbine inside high STC enclosure. • Low noise fans with inlet and exit silencers and larger footprint.
--	---

Mitigation: Action/Control	Responsibility	Timeframe
Construction Phase		
Maintenance of equipment and transport trucks.	Site engineer/ qualified construction employees	During construction period
Training of personnel to adhere to noise attenuation operational procedures.	Site engineer/ equipment operators	Initial training and seminars at regular intervals
Perimeter noise monitoring	Noise specialist	Biannual noise monitoring during construction lifespan
Operational Phase		
Incorporation of Substantial mitigation measures	Design engineers / Construction engineers	Throughout the operational lifespan
Proper maintenance of equipment	Site engineer/ qualified power station employees	Throughout the operational lifespan
Perimeter noise monitoring	Noise specialist	Annual noise monitoring throughout the operational lifespan

Performance Indicator	<ul style="list-style-type: none"> • The measured noise levels around the boundary of the site to be less than 70 dBA during day-time and 60 dBA during night-time. • The noise levels in Avondale and Protea Park residential areas not to exceed 50 dBA and 45 dBA during daytime and night-time respectively, due to the power station operations.
Monitoring	<p>Noise monitoring should be performed biannually during construction and annually during the operational phase by a noise specialist. The closest residential area to the site and at two selected locations outside the perimeter should also be included.</p> <p>The noise monitoring should be performed in accordance with SANS 10103 and the report submitted to the appropriate authority.</p>

REFERENCES

Commission of the European Communities (2000). Proposal for a Directive of the European Parliament and of the Council relating to the Assessment and Management of Environmental Noise. Commission of the European Communities COM(2000) 468 final, Brussels.

DEAT, 1992. Noise Control Regulations (Section 25). Environmental Conservation Act 73 of 1989. Gov. Gaz. No. 13717, 10 January 1992.

Environmental Conservation Act, 1989 (Act 73 of 1989). Noise Control Regulations.

South African National Standards (SANS) 10103:2008. The measurement and rating of environmental noise with respect to land use, health, annoyance and to speech communication.

APPENDIX A

❖ Noise Monitoring Locations

- **Position MP1 (Atl.01)**

Access – Easy, from Neil Hare Road northbound, left into dead-end street between the north-eastern Ankerlig site boundary and existing industrial plant.

Position – 1 m from existing industrial plant's south-western boundary

GPS co-ordinates – S33°3.190' E18°28.250'



View east along the north-eastern boundary of the site



View north away from the Ankerlig site

- **Position MP2 (Atl.02)**

Access – Easy, from R307 northbound, right into Atlantis residential area, on Gouba Street. Right into Grosvenor Avenue south bound until reaching the southern boundary of Avondale.

Position – 3 m south from the edge of the Bon Aventure Avenue, towards Ankerlig Power Station.

GPS co-ordinates – S33°34.437' E18°28.949'



View east with the site to the right



View north towards the Atlantis Community

- **Position MP3 (Atl.03)**

Access – Easy, from R307, opposite the Ankerlig Power Station, next to West Coast Biosphere Reserve entrance.

Position – 1 m from existing manhole.

GPS co-ordinates – S33°35.411' E18°27.529'



View northeast with the Ankerlig site ahead



View southeast with the site to the left

Measurement Table

Date - Time	Pos	Ins. Pos	Location	T (C°)	RH (%)	B	W (m/s)	L _{Aeq,L} (dBA)	L _{Amin} (dBA)	L _{Amax} (dBA)	L ₉₀ (dBA)	L ₅₀ (dBA)	L ₁₀ (dBA)	L ₁ (dBA)	Comments
8/04/08 – 12:43	Atl.01	P65	At industrial	25.9	32.6	1001	3.5	50.8	44.6	58.2	47.1	49.8	53	56.7	Construction, plane, passing vehicles and factory hum audible
8/04/08 – 20:06	Atl.01	P69	At industrial	21.8	55.9	999.7	1.4	52.5	50	64.6	50.8	51.9	53.1	57.7	Factory noise, forklift and container, insect and truck horn audible
8/04/08 – 22:44	Atl.01	P76	At industrial	14.1	80.8	1001	0.3	52.2	49.7	55.9	50.6	51.9	53.4	54.7	Earthmoving equips. ,factory hum and rd. audible
9/04/08 – 09:18	Atl.01	P79	At industrial	20.2	62.3	999.8	1.7	49	46	58.1	46.9	48.3	50.3	54.3	Earthmoving, factory hum, reverse horns, plane and rd., audible
9/04/08 – 14:08	Atl.01	P92	At industrial	31.3	22.1	998	1.4	49.2	44.8	60.7	46.2	47.9	50.7	56.8	Earthmoving equips. , factory hum, reverse horns, birds, plane and car horn audible
9/04/08 – 14:19	Atl.01	P93	At industrial	31.1	28.8	997.9	1.8	49	44.9	59.2	46.5	48	50.6	54.3	Same as previous except for car horn
9/04/08 – 23:31	Atl.01	P98	At industrial	17.8	75.2	997.7	1.3	53.2	48.8	59	51.1	53.1	54.1	56.5	Earthmoving equip., factory hum and insect noises audible
8/04/08 – 10:09	Atl.02	P59	At community	23.6	40.4	999.9	2.5	44.7	38.7	57.3	40.2	42	47.8	53.7	Voices across rd. audible
8/04/08 – 13:17	Atl.02	P67	At community	27.7	37.1	998.7	1.3	46.5	39.1	61.5	40.9	43.5	47.7	57.3	Birds, voices, construction, dog barking, vehicles and plane audible
8/04/08 – 20:41	Atl.02	P71	At community	17	73.8	999.5	0	52.7	46.2	69.8	47.6	49	52.8	63.1	Factory, earthmoving and vehicles audible
8/04/08 – 23:19	Atl.02	P78	At community	14	77.4	998.9	0.2	51.7	45.8	68.1	47.1	48.9	51.4	63.1	Police sirens, factory hum and dogs barking

9/04/08 – 09:53	Atl.02	P81	At community	22.9	52.9	997.2	1.1	48.5	40.9	68.6	41.9	43.8	47.7	59.5	Factory and earthmoving, reverse horns, surrounding rds., dogs barking and voices in background
9/04/08 – 13:11	Atl.02	P88	At community	28.6	38.6	995.7	2.2	54.8	39.3	77.3	40.3	42.5	53.5	68	Earthmoving, reverse horns, birds, kids playing and trucks in background audible
9/04/08 – 13:21	Atl.02	P89	At community	29.3	35.6	995.7	1.8	45.4	38.5	59.6	40.3	41.8	47.9	56.1	Same as previous only music audible in background
9/04/08 – 22:54	Atl.02	P96	At community	17.2	74	995.6	1.3	48.8	42.7	64.4	43.7	45.5	48.7	62.1	Earthmoving equip., factory hum, vehicles and dog barking audible
8/04/08 – 09:44	Atl.03	P58	Behind station	21.7	36.8	1003	2.3	56.1	45	67.2	47.4	53	60.1	63.4	Construction, passing vehicles and truck reverse horn audible
8/04/08 – 12:58	Atl.03	P66	Behind station	27	35	1002	1.4	50.6	39.9	64.5	41.4	45.4	54	61.3	Vehicles, factory and earthmoving equip. audible
8/04/08 – 20:22	Atl.03	P70	Behind station	19	66.6	1001	1.5	53.1	45.4	68.3	46.3	47.9	55.4	64.3	Factory hum, vehicles and horn audible
8/04/08 – 23:00	Atl.03	P77	Behind station	14.3	83.8	1003	1.1	51.6	45.8	62.5	47.1	48.6	55	60.3	Factory hum
9/04/08 – 09:35	Atl.03	P80	Behind station	21.1	62.9	1001	1.7	58.8	45	69.3	50	56.6	62.6	66.9	Construction/earthmovings, reverse horns, rd. and plane audible
9/04/08 – 13:39	Atl.03	P90	Behind station	30.3	35.4	999.4	2.9	52	41.3	64.9	44.8	49	55.3	60.4	Earthmoving, reverse horns, plane and rd. audible
9/04/08 – 13:51	Atl.03	P91	Behind station	35.2	22.1	999.6	2.9	52.9	41.3	69.2	44	48.8	56.1	62.2	Same as previous
9/04/08 – 23:13	Atl.03	P97	Behind station	16.4	74.4	999.5	1.1	49.6	45.9	58.6	46.9	48.1	51.5	57.2	Earthmoving equip., factory hum and road audible

APPENDIX B

Noise Model Sound Power Input Data

Operational Phase Equipment Sound Power Emissions

The modelling set-up was based on information provided by the Siemens report and the B&V engineers. The table below shows the noise power levels of all the major noise sources for the various phases of the Ankerlig Power Station.

Table B-1. Open Cycle and Combined Cycle Equipment Sound Power Emission Levels

Description	Source ID	Sound Power	Unit	Daytime Operation	Night-time Operation	Coordinates		
				(min)	(min)	(X)	(Y)	(Z)
11_Air_Exh_Un_N	11	85	dBA	960	480	-50091	-3718500	128
11_Air_Exh_Un_S	11	88	dBA	960	480	-50088	-3718503	128
11_Air_Sup_Op_E	11	93.6	dBA	960	480	-50059	-3718495	128
11_Air_Sup_Op_N	11	84.5	dBA	960	480	-50068	-3718487	129
11_Air_Sup_Op_S	11	88.6	dBA	960	480	-50052	-3718539	128
11_CW_URB	11	103.2	dBA	960	480	-50092	-3718467	131
11_GT_Diff_MBR	11	106.1	dBA	960	480	-50085	-3718496	129
11_GT_Intk_MBL	11	99.4	dBA	960	480	-50069	-3718511	142
11_OCI_URC	11	99	dBA	960	480	-50079	-3718480	130
11_St_LS_UHN	11	104.1	dBA	960	480	-50091	-3718491	135
11_Trif_BAT	11	100.2	dBA	960	480	-50034	-3718528	129
11_Air_Sup_Op_N	12	84.5	dBA	960	480	-50095	-3718516	128
11_Air_Sup_Op_E	12	93.6	dBA	960	480	-50087	-3718524	127

11_Air_Sup_Op_S	12	88.6	dBA	960	480	-50079	-3718568	127
11_Air_Exh_Un_N	12	85	dBA	960	480	-50118	-3718529	127
11_Air_Exh_Un_S	12	88	dBA	960	480	-50115	-3718532	127
11_GT_Intk_MBL	12	99.4	dBA	960	480	-50096	-3718540	141
11_GT_Diff_MBR	12	106.1	dBA	960	480	-50112	-3718526	128
11_St_LS_UHN	12	104.1	dBA	960	480	-50118	-3718520	134
11_OCI_URC	12	99	dBA	960	480	-50106	-3718510	129
11_CW_URB	12	103.2	dBA	960	480	-50119	-3718497	130
11_Trif_BAT	12	100.2	dBA	960	480	-50061	-3718557	128
11_Air_Sup_Op_N	21	84.5	dBA	960	480	-50153	-3718578	127
11_Air_Sup_Op_E	21	93.6	dBA	960	480	-50144	-3718586	127
11_Air_Sup_Op_S	21	88.6	dBA	960	480	-50137	-3718629	127
11_Air_Exh_Un_N	21	85	dBA	960	480	-50176	-3718591	127
11_Air_Exh_Un_S	21	88	dBA	960	480	-50173	-3718594	127
11_GT_Intk_MBL	21	99.4	dBA	960	480	-50153	-3718602	141
11_GT_Diff_MBR	21	106.1	dBA	960	480	-50170	-3718587	128
11_St_LS_UHN	21	104.1	dBA	960	480	-50175	-3718582	134
11_OCI_URC	21	99	dBA	960	480	-50164	-3718571	128
11_CW_URB	21	103.2	dBA	960	480	-50176	-3718558	129
11_Trif_BAT	21	100.2	dBA	960	480	-50118	-3718619	128
11_Ununden	21	0	dBA	960	480	-50161	-3718595	136
11_Air_Sup_Op_N	22	84.5	dBA	960	480	-50180	-3718607	127
11_Air_Sup_Op_E	22	93.6	dBA	960	480	-50171	-3718615	127
11_Air_Sup_Op_S	22	88.6	dBA	960	480	-50164	-3718659	127
11_Air_Exh_Un_N	22	85	dBA	960	480	-50203	-3718620	127
11_Air_Exh_Un_S	22	88	dBA	960	480	-50200	-3718623	127
11_GT_Intk_MBL	22	99.4	dBA	960	480	-50180	-3718631	141
11_GT_Diff_MBR	22	106.1	dBA	960	480	-50197	-3718616	128

11_St_LS_UHN	22	104.1	dBa	960	480	-50202	-3718611	134
11_OCI_URC	22	99	dBa	960	480	-50191	-3718600	128
11_CW_URB	22	103.2	dBa	960	480	-50203	-3718587	129
11_Trif_BAT	22	100.2	dBa	960	480	-50145	-3718648	128
11_Air_Sup_Op_N	31	84.5	dBa	960	480	-49735	-3718129	135
11_Air_Sup_Op_E	31	93.6	dBa	960	480	-49726	-3718137	135
11_Air_Sup_Op_S	31	88.6	dBa	960	480	-49719	-3718181	135
11_Air_Exh_Un_N	31	85	dBa	960	480	-49758	-3718142	134
11_Air_Exh_Un_S	31	88	dBa	960	480	-49755	-3718145	134
11_GT_Intk_MBL	31	99.4	dBa	960	480	-49735	-3718153	149
11_GT_Diff_MBR	31	106.1	dBa	960	480	-49752	-3718139	136
11_St_LS_UHN	31	104.1	dBa	960	480	-49757	-3718133	142
11_OCI_URC	31	99	dBa	960	480	-49746	-3718123	136
11_CW_URB	31	103.2	dBa	960	480	-49759	-3718110	137
11_Trif_BAT	31	100.2	dBa	960	480	-49700	-3718170	136
11_Air_Sup_Op_N	32	84.5	dBa	960	480	-49762	-3718159	135
11_Air_Sup_Op_E	32	93.6	dBa	960	480	-49753	-3718167	135
11_Air_Sup_Op_S	32	88.6	dBa	960	480	-49746	-3718210	135
11_Air_Exh_Un_N	32	85	dBa	960	480	-49785	-3718172	134
11_Air_Exh_Un_S	32	88	dBa	960	480	-49782	-3718174	134
11_GT_Intk_MBL	32	99.4	dBa	960	480	-49762	-3718183	149
11_GT_Diff_MBR	32	106.1	dBa	960	480	-49779	-3718168	136
11_St_LS_UHN	32	104.1	dBa	960	480	-49784	-3718162	141
11_OCI_URC	32	99	dBa	960	480	-49773	-3718152	136
11_CW_URB	32	103.2	dBa	960	480	-49786	-3718139	137
11_Trif_BAT	32	100.2	dBa	960	480	-49727	-3718199	136
11_Air_Sup_Op_N	41	84.5	dBa	960	480	-49789	-3718187	134
11_Air_Sup_Op_E	41	93.6	dBa	960	480	-49780	-3718195	134

11_Air_Sup_Op_S	41	88.6	dBA	960	480	-49773	-3718239	134
11_Air_Exh_Un_N	41	85	dBA	960	480	-49812	-3718200	134
11_Air_Exh_Un_S	41	88	dBA	960	480	-49809	-3718203	134
11_GT_Intk_MBL	41	99.4	dBA	960	480	-49789	-3718211	148
11_GT_Diff_MBR	41	106.1	dBA	960	480	-49806	-3718197	135
11_St_LS_UHN	41	104.1	dBA	960	480	-49811	-3718191	141
11_OCI_URC	41	99	dBA	960	480	-49800	-3718180	135
11_CW_URB	41	103.2	dBA	960	480	-49813	-3718168	136
11_Trif_BAT	41	100.2	dBA	960	480	-49754	-3718228	135
11_Air_Sup_Op_N	42	84.5	dBA	960	480	-49816	-3718217	134
11_Air_Sup_Op_E	42	93.6	dBA	960	480	-49808	-3718225	134
11_Air_Sup_Op_S	42	88.6	dBA	960	480	-49800	-3718269	134
11_Air_Exh_Un_N	42	85	dBA	960	480	-49839	-3718230	133
11_Air_Exh_Un_S	42	88	dBA	960	480	-49836	-3718233	133
11_GT_Intk_MBL	42	99.4	dBA	960	480	-49817	-3718241	148
11_GT_Diff_MBR	42	106.1	dBA	960	480	-49833	-3718226	135
11_St_LS_UHN	42	104.1	dBA	960	480	-49839	-3718221	140
11_OCI_URC	42	99	dBA	960	480	-49827	-3718210	135
11_CW_URB	42	103.2	dBA	960	480	-49840	-3718197	136
11_Trif_BAT	42	100.2	dBA	960	480	-49782	-3718258	135
11_Air_Sup_Op_N	43	84.5	dBA	960	480	-49843	-3718246	134
11_Air_Sup_Op_E	43	93.6	dBA	960	480	-49835	-3718254	134
11_Air_Sup_Op_S	43	88.6	dBA	960	480	-49827	-3718297	133
11_Air_Exh_Un_N	43	85	dBA	960	480	-49867	-3718259	133
11_Air_Exh_Un_S	43	88	dBA	960	480	-49864	-3718261	133
11_GT_Intk_MBL	43	99.4	dBA	960	480	-49844	-3718270	147
11_GT_Diff_MBR	43	106.1	dBA	960	480	-49861	-3718255	134
11_St_LS_UHN	43	104.1	dBA	960	480	-49866	-3718250	140

11_OCI_URC	43	99	dBa	960	480	-49854	-3718239	135
11_CW_URB	43	103.2	dBa	960	480	-49867	-3718226	136
11_Trf_BAT	43	100.2	dBa	960	480	-49809	-3718287	135
CC_BFP_Low	6221	102.6	dBa	960	480	-50107	-3718461	131
CC_BFP_High	6221	102.6	dBa	960	480	-50110	-3718459	131
CC_AUX_XFMR	6221	92.6	dBa	960	480	-50113	-3718456	130
CC_GSUT	6221	97.6	dBa	960	480	-50114	-3718454	132
CC_St_SO_UHN	6221	104.9	dBa	960	480	-50125	-3718458	177
CC_St_OD_UHN	6221	78.2	dBa	960	480	-50125	-3718459	157
CC_BFP_Low	6222	102.6	dBa	960	480	-50135	-3718490	130
CC_BFP_High	6222	102.6	dBa	960	480	-50137	-3718488	130
CC_AUX_XFMR	6222	92.6	dBa	960	480	-50140	-3718486	129
CC_GSUT	6222	97.6	dBa	960	480	-50142	-3718484	131
CC_St_SO_UHN	6222	104.9	dBa	960	480	-50153	-3718488	176
CC_St_OD_UHN	6222	78.2	dBa	960	480	-50152	-3718488	156
CC_BFP_Low	6223	102.6	dBa	960	480	-50192	-3718552	129
CC_BFP_High	6223	102.6	dBa	960	480	-50195	-3718549	129
CC_AUX_XFMR	6223	92.6	dBa	960	480	-50197	-3718547	128
CC_GSUT	6223	97.6	dBa	960	480	-50199	-3718545	130
CC_St_SO_UHN	6223	104.9	dBa	960	480	-50210	-3718549	175
CC_St_OD_UHN	6223	78.2	dBa	960	480	-50210	-3718549	155
CC_BFP_Low	6224	102.6	dBa	960	480	-49774	-3718104	137
CC_BFP_High	6224	102.6	dBa	960	480	-49777	-3718101	137
CC_AUX_XFMR	6224	92.6	dBa	960	480	-49779	-3718099	136
CC_GSUT	6224	97.6	dBa	960	480	-49781	-3718097	138
CC_St_SO_UHN	6224	104.9	dBa	960	480	-49792	-3718101	183
CC_St_OD_UHN	6224	78.2	dBa	960	480	-49792	-3718101	163
CC_BFP_Low	6225	102.6	dBa	960	480	-49802	-3718133	137