



An EOH Company

A 3D rendering of a globe with water splashing over it, set against a dark background. A large, faint infinity symbol is overlaid on the globe.

Innovation in
Sustainability

**BASIC ASSESSMENT FOR THE PROPOSED
ELECTRICITY EXPANSION PROJECT AND SEKGAME
SWITCHING STATION AT THE SISHEN MINE,
NORTHERN CAPE PROVINCE**

EOH

Prepared for: **Department of Environmental Affairs**

Prepared by: Exigo Sustainability (Pty) Ltd

TABLE OF CONTENTS

SECTION A: ACTIVITY INFORMATION	4
1. PROJECT DESCRIPTION	4
2. FEASIBLE AND REASONABLE ALTERNATIVES	5
a. Site alternatives	6
b. Lay-out alternatives	7
c. Technology alternatives	7
d. Other alternatives (e.g. scheduling, demand, input, scale and design alternatives)	7
e. No-go alternative	7
3. PHYSICAL SIZE OF THE ACTIVITY	8
a. Indicate the physical size of the preferred activity/technology as well as alternative activities/technologies (footprints):	8
b. Indicate the size of the alternative sites or servitudes (within which the above footprints will occur):	8
4. SITE ACCESS	8
5. LOCALITY MAP	8
6. LAYOUT / ROUTE PLAN	9
7. SENSITIVITY MAP	9
8. SITE PHOTOGRAPHS	9
9. FACILITY ILLUSTRATION	10
10. ACTIVITY MOTIVATION	10
11. APPLICABLE LEGISLATION, POLICIES AND/OR GUIDELINES	16
12. WASTE, EFFLUENT, EMISSION AND NOISE MANAGEMENT	17
13. WATER USE	19
14. ENERGY EFFICIENCY	19
SECTION B: SITE/AREA/PROPERTY DESCRIPTION	20
1. GRADIENT OF THE SITE	21
2. LOCATION IN LANDSCAPE	21
3. GROUNDWATER, SOIL AND GEOLOGICAL STABILITY OF THE SITE	21
4. GROUNDCOVER	22
5. SURFACE WATER	22
6. LAND USE CHARACTER OF SURROUNDING AREA	22
7. CULTURAL/HISTORICAL FEATURES	23
8. SOCIO-ECONOMIC CHARACTER	24
9. BIODIVERSITY	26
SECTION C: PUBLIC PARTICIPATION	31
1. ADVERTISEMENT AND NOTICE	31
2. DETERMINATION OF APPROPRIATE MEASURES	31
3. ISSUES RAISED BY INTERESTED AND AFFECTED PARTIES	32
4. COMMENTS AND RESPONSE REPORT	32
5. AUTHORITY PARTICIPATION	32
6. CONSULTATION WITH OTHER STAKEHOLDERS	34
SECTION D: IMPACT ASSESSMENT	35
1. IMPACTS THAT MAY RESULT FROM THE PLANNING AND DESIGN, CONSTRUCTION, OPERATIONAL, DECOMMISSIONING AND CLOSURE PHASES AS WELL AS PROPOSED MANAGEMENT OF IDENTIFIED IMPACTS AND PROPOSED MITIGATION MEASURES	35
2. ENVIRONMENTAL IMPACT STATEMENT	37
Section E. Recommendation of practitioner	39
Section F: Appendixes	40
Appendix A: Maps	41
Appendix B: Photographs	48

BASIC ASSESSMENT REPORT

Appendix C: Facility illustration(s)	49
Appendix D: Specialist reports (including terms of reference)	51
Appendix E: Public Participation	52
Appendix F: Impact Assessment	53
Appendix G: Environmental Management Programme (EMPr)	65
Appendix H: Details of EAP and expertise	66
Appendix I: Specialist's declaration of interest	67
Appendix J: Additional Information	68

LIST OF FIGURES

Figure 1: Vegetation Map	30
Figure 2: Locality of the Sishen Mine	42
Figure 3: Locality Map - Preferred Alternative	43
Figure 4: Locality Map showing Alternatives	44
Figure 5: Layout / Route Plan: Preferred	45
Figure 6: Layout / Route Plan for Alternatives	46
Figure 7: Sensitivity Map	47
Figure 8: Sekgame Project Layout	49
Figure 9: Switching Yard Facility Illustration	50



environmental affairs

Department:
Environmental Affairs
REPUBLIC OF SOUTH AFRICA

(For official use only)

File Reference Number:

Application Number:

Date Received:

Basic assessment report in terms of the Environmental Impact Assessment Regulations, 2014, promulgated in terms of the National Environmental Management Act, 1998 (Act No. 107 of 1998), as amended.

Kindly note that:

1. This **basic assessment report** is a standard report that may be required by a competent authority in terms of the EIA Regulations, 2014 and is meant to streamline applications. Please make sure that it is the report used by the particular competent authority for the activity that is being applied for.
2. This report format is current as of **08 December 2014**. It is the responsibility of the applicant to ascertain whether subsequent versions of the form have been published or produced by the competent authority
3. The report must be typed within the spaces provided in the form. The size of the spaces provided is not necessarily indicative of the amount of information to be provided. The report is in the form of a table that can extend itself as each space is filled with typing.
4. Where applicable **tick** the boxes that are applicable in the report.
5. An incomplete report may be returned to the applicant for revision.
6. The use of "not applicable" in the report must be done with circumspection because if it is used in respect of material information that is required by the competent authority for assessing the application, it may result in the rejection of the application as provided for in the regulations.
7. This report must be handed in at offices of the relevant competent authority as determined by each authority.
8. No faxed or e-mailed reports will be accepted.
9. The signature of the EAP on the report must be an original signature.
10. The report must be compiled by an independent environmental assessment practitioner.
11. Unless protected by law, all information in the report will become public information on receipt by the competent authority. Any interested and affected party should be provided with the information contained in this report on request, during any stage of the application process.
12. A competent authority may require that for specified types of activities in defined situations only parts of this report need to be completed.
13. Should a specialist report or report on a specialised process be submitted at any stage for any part of this application, the terms of reference for such report must also be submitted.
14. Two (2) colour hard copies and one (1) electronic copy of the report must be submitted to the competent authority.
15. Shape files (.shp) for maps must be included in the electronic copy of the report submitted to the competent authority.

BASIC ASSESSMENT REPORT

SECTION A: ACTIVITY INFORMATION

Has a specialist been consulted to assist with the completion of this section?

YES	NO
----------------	----

If YES, please complete the form entitled "Details of specialist and declaration of interest" for the specialist appointed and attach in **Appendix I**.

1. PROJECT DESCRIPTION

a) Describe the project associated with the listed activities applied for

<p>Kumba Iron Ore, Sishen Iron Ore Pty Ltd plans to develop additional electricity distribution infrastructure at their Sishen Iron Ore Mine in the Northern Cape Province.</p> <p>The proposed electricity distribution infrastructure will tie in with existing electricity distribution infrastructure at Sishen Mine and involve the following:</p> <ul style="list-style-type: none"> • 80 meter wide servitude from Ferrum Substation along the N14 road to the proposed new Sekgame Switching Station South of the Shooting Range Servitude • Distribution lines (132kV overhead lines) • Switching yard (Sekgame) • The switching yard will be approximately 110 meters from the N14 Road, 250 meters long and 100 meters wide. <p>Eskom will be responsible for the construction, operation and maintenance of the infrastructure.</p>

b) Provide a detailed description of the listed activities associated with the project as applied for

Listed activity as described in GN 734, 735 and 736	Description of project activity
<p>Example: GN 734 Item xx xx): The construction of a bridge where such construction occurs within a watercourse or within 32 metres of a watercourse, measured from the edge of a watercourse, excluding where such construction will occur behind the development setback line.</p>	<p>A bridge measuring 5 m in height and 10m in length, no wider than 8 meters will be built over the Orange river</p>
<p>GNR 983 of 2014 Activity No 11 The development of facilities or infrastructure for the transmission and distribution of electricity- (i) outside urban areas or industrial complexes with a capacity of more than 33 but less than 275 kilovolts;</p>	<p>The Project involves the development of electricity distribution lines (132kV overhead lines)</p>
<p>GNR 983 of 2014 Activity No 27 The clearance of an area of 1 hectares or more, but less than 20 hectares of indigenous vegetation, except where such clearance of indigenous vegetation is required for- (i) the undertaking of a linear activity; or (ii) maintenance purposes undertaken in accordance with a maintenance management Plan</p>	<p>The clearance of indigenous vegetation would be required for the development of the Sekgame Switching Yard</p>
<p>GNR 983 of 2014 Activity No 47 The expansion of facilities or infrastructure for the transmission and distribution of electricity where</p>	<p>In this project, the development footprint of the electricity distribution infrastructure at Sishen Mine</p>

BASIC ASSESSMENT REPORT

<p>the expanded capacity will exceed 275 kilovolts and the development footprint will increase.</p>	<p>will increase.</p>
<p>GNR 985 of 2014 Activity No 12 The clearance of an area of 300 square metres or more of indigenous vegetation except where such clearance of indigenous vegetation is required for maintenance purposes undertaken in accordance with a maintenance management plan. (d) In Northern Cape: i. Within any critically endangered or endangered ecosystem listed in terms of section 52 of the NEMBA 'or prior to the publication of such a list, within an area that has been identified as critically endangered in the National Spatial Biodiversity Assessment 2004; ii. Within critical biodiversity areas identified in bioregional plans; iii. Within the littoral active zone or 100 metres inland from high water mark of the sea or an estuary, whichever distance is the greater, excluding where such removal will occur behind the development setback line on erven in urban areas; or iv. On land, where, at the time of the coming into effect of this Notice or thereafter such land was zoned open space, conservation or had an equivalent zoning.</p>	<p>Clearance of Vegetation will be required for the construction of the Distribution lines and the switching yard.</p>

2. FEASIBLE AND REASONABLE ALTERNATIVES

“alternatives”, in relation to a proposed activity, means different means of meeting the general purpose and requirements of the activity, which may include alternatives to—

- (a) the property on which or location where it is proposed to undertake the activity;
- (b) the type of activity to be undertaken;
- (c) the design or layout of the activity;
- (d) the technology to be used in the activity;
- (e) the operational aspects of the activity; and
- (f) the option of not implementing the activity.

Describe alternatives that are considered in this application as required by Appendix 1 (3)(h), Regulation 2014. Alternatives should include a consideration of all possible means by which the purpose and need of the proposed activity (NOT PROJECT) could be accomplished in the specific instance taking account of the interest of the applicant in the activity. The no-go alternative must in all cases be included in the assessment phase as the baseline against which the impacts of the other alternatives are assessed.

The determination of whether site or activity (including different processes, etc.) or both is appropriate needs to be informed by the specific circumstances of the activity and its environment. After receipt of this report the, competent authority may also request the applicant to assess additional alternatives that could possibly accomplish the purpose and need of the proposed activity if it is clear that realistic alternatives have not been considered to a reasonable extent.

BASIC ASSESSMENT REPORT

The identification of alternatives should be in line with the Integrated Environmental Assessment Guideline Series 11, published by the DEA in 2004. Should the alternatives include different locations and lay-outs, the co-ordinates of the different alternatives must be provided. The co-ordinates should be in degrees, minutes and seconds. The projection that must be used in all cases is the WGS84 spheroid in a national or local projection.

a. Site alternatives

Alternative 1 (preferred alternative)		
Description	Lat (DDMMSS)	Long (DDMMSS)
The preferred alternative is illustrated in Figure 3 and Figure 5 in Appendix A. The route is from the existing Ferrum Substation to the N14, South along the N14 (between the highway and existing Shooting Range Servitude) to the proposed Sekgame Switching Station position south of the Shooting Range servitude. The approximate centre of the Switching Yard position is given:	27°46'33.14"S	23° 3'55.96"E
Alternative 2		
Description	Lat (DDMMSS)	Long (DDMMSS)
Alternative 2 (Figure 4 and Figure 6 – Appendix A): it was considered to move the position of the preferred Sekgame Switching station as indicated. This however interferes with possible future plans on the existing Shooting Range Servitude. Alternative coordinates for the switching station (approximate centre) is given.	27°45'41.41"S	23° 3'58.68"E
Alternative 3		
Description	Lat (DDMMSS)	Long (DDMMSS)
Alternative 3 (Figure 4 and Figure 6 – Appendix A) involved an extension of the infrastructure to the south, to just north of the Gamagara River. It was subsequently identified that this option holds no economic merit for the developer at this stage. The switching yard position in the case of this alternative would be the same as for the preferred alternative	27°46'33.14"S	23° 3'55.96"E

In the case of linear activities:

Alternative:

Alternative S1 (preferred)

- Starting point of the activity
- Middle/Additional point of the activity
- End point of the activity

Latitude (S):

Longitude (E):

27°43 '53.39"S	23°3 '43.10"E
27°46'21.27"S	23°4'2.53"E
27°46'31.38"S	23°3'51.84"E

Alternative S2 (if any)

- Starting point of the activity
- Middle/Additional point of the activity
- End point of the activity

27°43 '53.39"S	23°3 '43.10"E
27°44'18.68"S	23°4'10.79"E
27°46'46.07"S	23° 4'0.68"E

Alternative S3 (if any)

- Starting point of the activity
- Middle/Additional point of the activity
- End point of the activity

27°43 '53.39"S	23°3 '43.10"E
27°46'31.38"S	23°3'51.84"E
27°49'6.64"S	23° 2'9.19"E

BASIC ASSESSMENT REPORT

For route alternatives that are longer than 500m, please provide an addendum with co-ordinates taken every 250 meters along the route for each alternative alignment. Please refer to Appendix J

In the case of an area being under application, please provide the co-ordinates of the corners of the site as indicated on the lay-out map provided in Appendix A of this form.

b. Lay-out alternatives

Alternative 1 (preferred alternative)		
Description	Lat (DDMMSS)	Long (DDMMSS)
As described above		
Alternative 2		
Description	Lat (DDMMSS)	Long (DDMMSS)
As described above		
Alternative 3		
Description	Lat (DDMMSS)	Long (DDMMSS)
As described above		

c. Technology alternatives

Alternative 1 (preferred alternative)
Best Available Technology will be used as per the Eskom Guidelines
Alternative 2
Alternative 3

d. Other alternatives (e.g. scheduling, demand, input, scale and design alternatives)

Alternative 1 (preferred alternative)
Alternative 2
Alternative 3

e. No-go alternative

The implementation of the No-Go alternative (or the no-development option) would mean that the site will be left in its current state. The status quo of the site would thus be maintained, and none of the identified potential impacts would be realized. However, none of the project benefits would be realized either and the Sishen Mine and other Mine's in the area are likely to experience shortages in electricity rendering them unable to continue with mining and mining expansion projects that require electricity.

Thus the direct impacts of implementing the no-development option lies primarily in the employment opportunities associated with the construction and maintenance of the infrastructure that would not be realized. Cumulatively, not implementing the proposed project could have significant negative effects on surrounding industries (including Sishen Mine) and all of the Socio-economic benefits associated with those projects requiring electricity.

Paragraphs 3 – 13 below should be completed for each alternative.

3. PHYSICAL SIZE OF THE ACTIVITY

a. Indicate the physical size of the preferred activity/technology as well as alternative activities/technologies (footprints):

Alternative:

Alternative A1¹ (preferred activity alternative)
 Alternative A2 (if any)
 Alternative A3 (if any)

Size of the activity:

	m ²
	m ²
	m ²

or, for linear activities:

Alternative:

Alternative A1 (preferred activity alternative)
 Alternative A2 (if any)
 Alternative A3 (if any)

Length of the activity:

Approximately 5800 m
Approximately 4000 m
Approximately 11400 m

b. Indicate the size of the alternative sites or servitudes (within which the above footprints will occur):

Alternative:

Alternative A1 (preferred activity alternative)
 Alternative A2 (if any)
 Alternative A3 (if any)

Size of the site/servitude:

Approximately 895 000 m ²
Approximately 850 000 m ²
Approximately 1 735 000 m ²

4. SITE ACCESS

Does ready access to the site exist?

If NO, what is the distance over which a new access road will be built

YES	NO
m	

Describe the type of access road planned:

The site (servitude) is adjacent to the N14 Highway. The switching yard will be approximately 110 m away from the N14 Highway. The site can be accessed from the Highway to the east of the site, or from Sishen mine areas to the west of the site.

Include the position of the access road on the site plan and required map, as well as an indication of the road in relation to the site.

5. LOCALITY MAP

An A3 locality map must be attached to the back of this document, as **Appendix A**. The scale of the locality map must be relevant to the size of the development (at least 1:50 000. For linear activities of more than 25 kilometres, a smaller scale e.g. 1:250 000 can be used. The scale must be indicated on the map.). The map must indicate the following:

- an accurate indication of the project site position as well as the positions of the alternative sites, if any;
- indication of all the alternatives identified;

¹ "Alternative A." refer to activity, process, technology or other alternatives.

- closest town(s);
- road access from all major roads in the area;
- road names or numbers of all major roads as well as the roads that provide access to the site(s);
- all roads within a 1km radius of the site or alternative sites; and
- a north arrow;
- a legend; and
- locality GPS co-ordinates (Indicate the position of the activity using the latitude and longitude of the centre point of the site for each alternative site. The co-ordinates should be in degrees and decimal minutes. The minutes should have at least three decimals to ensure adequate accuracy. The projection that must be used in all cases is the WGS84 spheroid in a national or local projection).

6. LAYOUT / ROUTE PLAN

A detailed site or route plan(s) must be prepared for each alternative site or alternative activity. It must be attached as Appendix A to this document.

The site or route plans must indicate the following:

- the property boundaries and numbers of all the properties within 50 metres of the site;
- the current land use as well as the land use zoning of the site;
- the current land use as well as the land use zoning each of the properties adjoining the site or sites;
- the exact position of each listed activity applied for (including alternatives);
- servitude(s) indicating the purpose of the servitude;
- a legend; and
- a north arrow.

7. SENSITIVITY MAP

The layout/route plan as indicated above must be overlain with a sensitivity map that indicates all the sensitive areas associated with the site, including, but not limited to:

- watercourses;
- the 1:100 year flood line (where available or where it is required by DWS);
- ridges;
- cultural and historical features;
- areas with indigenous vegetation (even if it is degraded or infested with alien species); and
- critical biodiversity areas.

The sensitivity map must also cover areas within 100m of the site and must be attached in Appendix A.

8. SITE PHOTOGRAPHS

Colour photographs from the centre of the site must be taken in at least the eight major compass directions with a description of each photograph. Photographs must be attached under Appendix B to this report. It must be supplemented with additional photographs of relevant features on the site, if applicable.

9. FACILITY ILLUSTRATION

A detailed illustration of the activity must be provided at a scale of at least 1:200 as Appendix C for activities that include structures. The illustrations must be to scale and must represent a realistic image of the planned activity. The illustration must give a representative view of the activity.

10. ACTIVITY MOTIVATION

Motivate and explain the need and desirability of the activity (including demand for the activity):

1. Is the activity permitted in terms of the property's existing land use rights?	<input checked="" type="checkbox"/> YES	<input type="checkbox"/> NO	Please explain
There is existing electricity distribution infrastructure along portions of the road and it is thus assumed that expansion is permitted. Eskom will verify the servitude land use rights prior to construction commencing.			
2. Will the activity be in line with the following?			
(a) Provincial Spatial Development Framework (PSDF)	<input checked="" type="checkbox"/> YES	<input type="checkbox"/> NO	Please explain
The PSDF mentions plans to expand electricity infrastructure from Ferrum to Groblershoop, and emphasizes the importance of mining in the Province. Therefore though the project is more specifically focussed on addressing the needs of the Sishen Mine, it is definitely not in contrast with Provincial Planning.			
(b) Urban edge / Edge of Built environment for the area	<input checked="" type="checkbox"/> YES	<input type="checkbox"/> NO	Please explain
The project will be an extension / expansion of existing facilities in the immediate surroundings and due to its close proximity to Sishen Mine will not be in contrast to existing development types.			
(c) Integrated Development Plan (IDP) and Spatial Development Framework (SDF) of the Local Municipality (e.g. would the approval of this application compromise the integrity of the existing approved and credible municipal IDP and SDF?).	<input checked="" type="checkbox"/> YES	<input type="checkbox"/> NO	Please explain
The Gamagara Local Municipality IDP and SDF also recognize the importance of mining in the area, and specifically the Sishen Mine			
(d) Approved Structure Plan of the Municipality	<input checked="" type="checkbox"/> YES	<input type="checkbox"/> NO	Please explain
The Gamagara Local Municipality IDP and SDF also recognize the importance of mining in the area, and specifically the Sishen Mine			
(e) An Environmental Management Framework (EMF) adopted by the Department (e.g. Would the approval of this application compromise the integrity of the existing environmental management priorities for the area and if so, can it be justified in terms of sustainability considerations?)	<input checked="" type="checkbox"/> YES	<input type="checkbox"/> NO	Please explain
The project is located within the existing Mining Right Area of the Sishen Mine, and immediately adjacent to the existing N14 Highway, and can therefore not be said to be in contrast with development and environmental priorities of the area.			
(f) Any other Plans (e.g. Guide Plan)	<input type="checkbox"/> YES	<input type="checkbox"/> NO	Please explain

BASIC ASSESSMENT REPORT

3. Is the land use (associated with the activity being applied for) considered within the timeframe intended by the existing approved SDF agreed to by the relevant environmental authority (i.e. is the proposed development in line with the projects and programmes identified as priorities within the credible IDP)?	<div style="border: 1px solid black; width: 40px; height: 40px; margin: 0 auto; display: flex; align-items: center; justify-content: center;"> X </div>	<div style="border: 1px solid black; width: 40px; height: 40px; margin: 0 auto; display: flex; align-items: center; justify-content: center;"> NO </div>	Please explain
The project time-frames align with planning authorities' intention to develop electricity infrastructure. Planning authorities recognize the value of the Sishen Mine in terms of its economic and socio-economic contribution to the area.			
4. Does the community/area need the activity and the associated land use concerned (is it a societal priority)? (This refers to the strategic as well as local level (e.g. development is a national priority, but within a specific local context it could be inappropriate.)	<div style="border: 1px solid black; width: 40px; height: 40px; margin: 0 auto; display: flex; align-items: center; justify-content: center;"> X </div>	<div style="border: 1px solid black; width: 40px; height: 40px; margin: 0 auto; display: flex; align-items: center; justify-content: center;"> NO </div>	Please explain
The activity will facilitate continuation of mining and beneficiation projects at Sishen Mine where a great number of members from surrounding communities work. Though the project is perhaps not truly a national priority (because of its intention to supply electricity to areas within Sishen Mine), it can certainly be said that the project is a priority for Sishen.			
5. Are the necessary services with adequate capacity currently available (at the time of application), or must additional capacity be created to cater for the development? (Confirmation by the relevant Municipality in this regard must be attached to the final Basic Assessment Report as Appendix I.)	<div style="border: 1px solid black; width: 40px; height: 40px; margin: 0 auto; display: flex; align-items: center; justify-content: center;"> YES </div>	<div style="border: 1px solid black; width: 40px; height: 40px; margin: 0 auto; display: flex; align-items: center; justify-content: center;"> X </div>	Please explain
Sufficient and appropriate electricity distribution infrastructure is not currently available at Sishen Mine, which is why this project was initiated.			
6. Is this development provided for in the infrastructure planning of the municipality, and if not what will the implication be on the infrastructure planning of the municipality (priority and placement of services and opportunity costs)? (Comment by the relevant Municipality in this regard must be attached to the final Basic Assessment Report as Appendix I.)	<div style="border: 1px solid black; width: 40px; height: 40px; margin: 0 auto; display: flex; align-items: center; justify-content: center;"> YES </div>	<div style="border: 1px solid black; width: 40px; height: 40px; margin: 0 auto; display: flex; align-items: center; justify-content: center;"> X </div>	Please explain
The project is not specifically provided for in the infrastructure planning of the Municipality, and is aimed at addressing the needs of the Sishen Mine Primarily. As the project will be constructed, operated and maintained by Eskom, there will be no implication for the Municipality.			
7. Is this project part of a national programme to address an issue of national concern or importance?	<div style="border: 1px solid black; width: 40px; height: 40px; margin: 0 auto; display: flex; align-items: center; justify-content: center;"> YES </div>	<div style="border: 1px solid black; width: 40px; height: 40px; margin: 0 auto; display: flex; align-items: center; justify-content: center;"> X </div>	Please explain
The project is mainly aimed at addressing the needs of the Sishen Mine in terms of electricity distribution			
8. Do location factors favour this land use (associated with the activity applied for) at this place? (This relates to the contextualisation of the proposed land use on this site within its broader context.)	<div style="border: 1px solid black; width: 40px; height: 40px; margin: 0 auto; display: flex; align-items: center; justify-content: center;"> X </div>	<div style="border: 1px solid black; width: 40px; height: 40px; margin: 0 auto; display: flex; align-items: center; justify-content: center;"> NO </div>	Please explain
The proposed project is compatible with its immediate surroundings			

BASIC ASSESSMENT REPORT

9. Is the development the best practicable environmental option for this land/site?	<input checked="" type="checkbox"/> YES	<input type="checkbox"/> NO	Please explain
The design, proposed construction and operation / maintenance of this infrastructure will be according to Eskom's Best Practice Guidelines and best practicable environmental options on the proposed site which is compatible with the proposed project.			
10. Will the benefits of the proposed land use/development outweigh the negative impacts of it?	<input checked="" type="checkbox"/> YES	<input type="checkbox"/> NO	Please explain
In the Impact Assessment section of this report we see that the environmental impacts associated with this project are manageable and acceptable. Implementation of this project will enable additional projects at Sishen Mine and all of the socio-economic benefits associated with the Mine operations.			
11. Will the proposed land use/development set a precedent for similar activities in the area (local municipality)?	<input type="checkbox"/> YES	<input checked="" type="checkbox"/> NO	Please explain
The project is aimed at addressing the increased electricity distribution needs for projects within the Sishen Mine boundary and is unlikely to set a precedent where similar needs do not exist.			
12. Will any person's rights be negatively affected by the proposed activity/ies?	<input type="checkbox"/> YES	<input checked="" type="checkbox"/> NO	Please explain
The project and associated activities will not affect anyone's rights as the project is located within the existing Sishen Mining Rights area, in existing servitudes designated for this purpose (relating to the distribution lines) and immediately adjacent to the Road (making alternative land uses on this particular property undesirable).			
13. Will the proposed activity/ies compromise the "urban edge" as defined by the local municipality?	<input type="checkbox"/> YES	<input checked="" type="checkbox"/> NO	Please explain
The proposed activity involves the development of electricity distribution infrastructure for the Sishen Mine and is immediately adjacent to the Sishen Mine.			
14. Will the proposed activity/ies contribute to any of the 17 Strategic Integrated Projects (SIPS)?	<input type="checkbox"/> YES	<input checked="" type="checkbox"/> NO	Please explain
SIP 5 refers to the Saldanha-Northern Cape development corridor and includes (among others) "Expansion of iron ore mining production and beneficiation." This project is not related to expansion of mining or beneficiation at the Sishen Iron Ore Mine but is supporting infrastructure to facilitate such further developments in future.			
15. What will the benefits be to society in general and to the local communities?	Please explain		
Construction personnel will be sourced from the nearest communities where possible, contributing to some job creation (even though temporary there is an opportunity for skills development). Additionally, the indirect benefits arising from this project lies in the continuation and expansion of activities at Sishen Mine, which is associated with significant socio-economic benefit for the communities in the vicinity (as an employer) and the country (as a producer of iron ore).			
16. Any other need and desirability considerations related to the proposed activity?	Please explain		
Explained above			
17. How does the project fit into the National Development Plan for 2030?	Please explain		
The project does not address the priorities of the National Development Plan directly but does have the aim of facilitating the expansion of projects within the existing Sishen Mine.			

18. Please describe how the general objectives of Integrated Environmental Management as set out in section 23 of NEMA have been taken into account.

The general objective of integrated environmental management, and the way in which the project takes these into account are set out below:

(a) promote the integration of the principles of environmental management set out in section 2 into the making of all decisions which may have a significant effect on the environment;

- The principles of IEM are discussed below

(b) identify, predict and evaluate the actual and potential impact on the environment, socio-economic conditions and cultural heritage, the risks and consequences and alternatives and options for mitigation of activities, with a view to minimising negative impacts, maximising benefits, and promoting compliance with the principles of environmental management set out in section 2;

- Refer to the Impact Assessment presented in Section D of this Report

(c) ensure that the effects of activities on the environment receive adequate consideration before actions are taken in connection with them;

- This process of applying for environmental authorization through conducting an environmental impact assessment and public consultation process

(d) ensure adequate and appropriate opportunity for public participation in decisions that may affect the environment;

- For details of the public participation process, refer to Section C of this Report

(e) ensure the consideration of environmental attributes in management and decision-making which may have a significant effect on the environment; and

- This process of applying for environmental authorization through conducting an environmental impact assessment along with relevant specialist studies (refer to Appendix D) addresses this objective

(f) identify and employ the modes of environmental management best suited to ensuring that a particular activity is pursued in accordance with the principles of environmental management set out in section 2.

- Environmental Management stipulations are given in detail in the Environmental Management Programme Report in Appendix G.

19. Please describe how the principles of environmental management as set out in section 2 of NEMA have been taken into account.

The following Principles apply

2. (1) The principles set out in this section apply throughout the Republic to the actions of all organs of state that may significantly affect the environment...

- The relevant department is the decision-making authority and application is made to them through the relevant and prescribed process for environmental authorization.

(2) Environmental management must place people and their needs at the forefront of its concern, and serve their physical, psychological, developmental, cultural and social interests equitably.

- The proposed project will not negatively impact on any person's interests

(3) Development must be socially, environmentally and economically sustainable.

- The proposed development will ensure the sustained development of the Sishen Mine, along with the socio-economic benefits associated therewith

(4) (a) Sustainable development requires the consideration of all relevant factors including the following: (i) That the disturbance of ecosystems and loss of biological diversity are avoided, or, where they cannot be altogether avoided, are minimised and remedied;

- Refer to the measures stipulated in the EMPR and the specialist ecological report

(ii) that pollution and degradation of the environment are avoided, or, where they cannot be altogether avoided, are minimised and remedied;

- Refer to the measures stipulated in the EMPR

(iii) that the disturbance of landscapes and sites that constitute the nation's cultural heritage is avoided, or where it cannot be altogether avoided, is minimised and remedied;

- Refer to the measures stipulated in the EMPR and the specialist archaeological report

(iv) that waste is avoided, or where it cannot be altogether avoided, minimised and re-used or recycled where possible and otherwise disposed of in a responsible manner;

- Refer to the measures stipulated in the EMPR

(v) that the use and exploitation of non-renewable natural resources is responsible and equitable, and takes into account the consequences of the depletion of the resource;

(vi) that the development, use and exploitation of renewable resources and the ecosystems of which they are part do not exceed the level beyond which their integrity is jeopardised;

- Not relevant to the proposed development as no non-renewable resources will be depleted and only very limited natural resources such as water for workers during the construction phase are associated with the proposed development

(vii) that a risk-averse and cautious approach is applied, which takes into account the limits of current knowledge about the consequences of decisions and actions; and

(viii) that negative impacts on the environment and on people's environmental rights be anticipated and prevented, and where they cannot be altogether prevented, are minimised and remedied.

- This environmental impact assessment process addresses the above 2 points, especially considering that the precautionary principle is adapted throughout the impact assessment.

(b) Environmental management must be integrated, acknowledging that all elements of the environment are linked and interrelated, and it must take into account the effects of decisions on all aspects of the environment and all people in the environment by pursuing the selection of the best practicable environmental option.

- To this end, this environmental impact assessment has considered all available alternatives to arrive at the preferred alternative and apply for environmental authorization for the development proposal.

BASIC ASSESSMENT REPORT

(c) Environmental justice must be pursued so that adverse environmental impacts shall not be distributed in such a manner as to unfairly discriminate against any person, particularly vulnerable and disadvantaged persons.

(d) Equitable access to environmental resources, benefits and services to meet basic human needs and ensure human well-being must be pursued and special measures may be taken to ensure access thereto by categories of persons disadvantaged by unfair discrimination.

- Environmental impacts associated with the proposed development are shown to be limited and manageable and extremely unlikely to lead to any discrimination, or to have any effect on another's access to environmental resources or benefits.

(e) Responsibility for the environmental health and safety consequences of a policy, programme, project, product, process, service or activity exists throughout its life cycle.

- Eskom's standard Health and Safety requirements will apply

(f) The participation of all interested and affected parties in environmental governance must be promoted, and all people must have the opportunity to develop the understanding, skills and capacity necessary for achieving equitable and effective participation, and participation by vulnerable and disadvantaged persons must be ensured.

- Please refer to Section C of this report for details on the public participation process followed and which is still ongoing.

(g) Decisions must take into account the interests, needs and values of all interested and affected parties, and this includes recognising all forms of knowledge, including traditional and ordinary knowledge.

- The Competent Authority will make decisions regarding this project

(h) Community wellbeing and empowerment must be promoted through environmental education, the raising of environmental awareness, the sharing of knowledge and experience and other appropriate means.

- Environmental awareness training is stipulated in the EMPR

(i) The social, economic and environmental impacts of activities, including disadvantages and benefits, must be considered, assessed and evaluated, and decisions must be appropriate in the light of such consideration and assessment.

- Please refer to the Impact Assessment, Section D

(j) The right of workers to refuse work that is harmful to human health or the environment and to be informed of dangers must be respected and protected.

- It is not anticipated that the work associated with the development proposal will be harmful as the EIA Process is completed in terms of the NEMA and Eskom's Health and Safety Policies will also apply.

(k) Decisions must be taken in an open and transparent manner, and access to information must be provided in accordance with the law.

- All relevant stakeholders will be granted access to this report and appendices thereto

(l) There must be intergovernmental co-ordination and harmonisation of policies, legislation and actions relating to the environment.

- A copy of this report has also been forwarded to other Government Departments, refer to Section C point 5.

(m) Actual or potential conflicts of interest between organs of state should be resolved through conflict resolution procedures.

- No conflicts have been identified as yet.

(n) Global and international responsibilities relating to the environment must be discharged in the national interest.

(o) The environment is held in public trust for the people, the beneficial use of environmental

BASIC ASSESSMENT REPORT

resources must serve the public interest and the environment must be protected as the people's common heritage.

(p) The costs of remedying pollution, environmental degradation and consequent adverse health effects and of preventing, controlling or minimising further pollution, environmental damage or adverse health effects must be paid for by those responsible for harming the environment.

- It is not anticipated that the proposed development will cause significant harm to the environment.

(q) The vital role of women and youth in environmental management and development must be recognised and their full participation therein must be promoted.

- The public participation process includes notification of all potentially interested and affected parties including women and youth.

(r) Sensitive, vulnerable, highly dynamic or stressed ecosystems, such as coastal shores, estuaries, wetlands, and similar systems require specific attention in management and planning procedures, especially where they are subject to significant human resource usage and development pressure.

- The proposed development site is not particularly sensitive or vulnerable – please refer to the Ecological Report in Appendix D.

11. APPLICABLE LEGISLATION, POLICIES AND/OR GUIDELINES

List all legislation, policies and/or guidelines of any sphere of government that are applicable to the application as contemplated in the EIA regulations, if applicable:

Title of legislation, policy or guideline	Applicability to the project	Administering authority	Date
The National Environmental Management Act (107 of 1998) (as amended)	Requires environmental authorization for Listed Activities	Department of Environmental Affairs (DEA). & Northern Cape Department of Environment & Nature Conservation (DENC)	1998
Environmental Impact Assessment Regulations	Requires environmental authorization for Listed Activities	DEA & DENC	2014
Listing Notice 1 Government Notice No. R 544	Requires environmental authorization for Listed Activities	DEA & DENC	2010
Listing Notice 3 Government Notice No. R 546	Requires environmental authorization for Listed Activities	DEA & DENC	2010
National Forests Act (Act 84 of 1998) (NFA)	Potential for protected trees on site to be retained or application made to DAFF is removal of these trees is unavoidable.	Department of Agriculture, Fisheries and Forestry	1998
The National Heritage Resources Act (Act 25 of 1999) (NHRA)	Heritage resources present on site – layout to be adjusted to avoid these resources, or Phase 2 assessment to be completed	The South African Heritage Resources Agency (SAHRA) and their provincial offices	1999
Integrated Environmental Management:	To ensure sustainable development and responsible environmental management takes place – refer to previous section for detailed discussion	DEA	1992
Conservation of Agricultural Resources Act (Act No. 43 of 1983)	Potential for alien invasive species to be present on site – to be removed in accordance with	Department of Agriculture	1983

BASIC ASSESSMENT REPORT

	CARA and DWA Guidelines		
Integrated Development Plan (IDP) Gamagara Local Municipality	The project should not be in contradiction with local development policies and plans.	Gamagara Local Municipality	2013/2014
John Taolo Gaetsewe District Municipality IDP		John Taolo Gaetsewe District Municipality	2012 - 2017
John Taolo Gaetsewe District Municipality Spatial Development Framework (SDF)		John Taolo Gaetsewe District Municipality	2012

12. WASTE, EFFLUENT, EMISSION AND NOISE MANAGEMENT

a) Solid waste management

Will the activity produce solid construction waste during the construction/initiation phase?

YES	NO
Insignificant m ³	

If YES, what estimated quantity will be produced per month?

How will the construction solid waste be disposed of (describe)?

To be disposed of by Eskom who will be responsible for the construction of the infrastructure.

Where will the construction solid waste be disposed of (describe)?

Likely taken off-Site by road truck and disposed of at registered landfill by specialist contractor or disposed of at Sishen Mine's Landfill.

Will the activity produce solid waste during its operational phase?

YES	NO
m ³	

If YES, what estimated quantity will be produced per month?

How will the solid waste be disposed of (describe)?

If the solid waste will be disposed of into a municipal waste stream, indicate which registered landfill site will be used.

Where will the solid waste be disposed of if it does not feed into a municipal waste stream (describe)?

If the solid waste (construction or operational phases) will not be disposed of in a registered landfill site or be taken up in a municipal waste stream, then the applicant should consult with the competent authority to determine whether it is necessary to change to an application for scoping and EIA.

Can any part of the solid waste be classified as hazardous in terms of the NEM:WA?

YES	NO
-----	---------------

If YES, inform the competent authority and request a change to an application for scoping and EIA. An application for a waste permit in terms of the NEM:WA must also be submitted with this application.

Is the activity that is being applied for a solid waste handling or treatment facility?

YES	NO
-----	---------------

If YES, then the applicant should consult with the competent authority to determine whether it is necessary to change to an application for scoping and EIA. An application for a waste permit in terms of the NEM:WA must also be submitted with this application.

b) Liquid effluent

Will the activity produce effluent, other than normal sewage, that will be disposed of in a municipal sewage system?

YES	NO
-----	---------------

If YES, what estimated quantity will be produced per month?

m ³

Will the activity produce any effluent that will be treated and/or disposed of on site?

YES	NO
-----	---------------

If YES, the applicant should consult with the competent authority to determine whether it is necessary to change to an application for scoping and EIA.

Will the activity produce effluent that will be treated and/or disposed of at another facility?

YES	NO
-----	---------------

If YES, provide the particulars of the facility:

Facility name:			
Contact person:			
Postal address:			
Postal code:			
Telephone:	Cell:		
E-mail:	Fax:		

Describe the measures that will be taken to ensure the optimal reuse or recycling of waste water, if any:

Very little water will be present on site: Potable water for construction workers will be provided. Some water may be required for mixing of concrete and general construction activities. This will be sourced either from the Mine or from the Local Municipality.

c) Emissions into the atmosphere

Will the activity release emissions into the atmosphere other than exhaust emissions and dust associated with construction phase activities?

YES	NO
-----	---------------

If YES, is it controlled by any legislation of any sphere of government?

YES	NO
-----	----

If YES, the applicant must consult with the competent authority to determine whether it is necessary to change to an application for scoping and EIA.

If NO, describe the emissions in terms of type and concentration:

Some dust may be generated by construction activities. Dust suppression via watering truck will be implemented on site if necessary.

d) Waste permit

Will any aspect of the activity produce waste that will require a waste permit in terms of the NEM:WA?

YES	NO
-----	---------------

If YES, please submit evidence that an application for a waste permit has been submitted to the competent authority

e) Generation of noise

Will the activity generate noise?

YES	NO
YES	NO

If YES, is it controlled by any legislation of any sphere of government?

BASIC ASSESSMENT REPORT

Describe the noise in terms of type and level:

Generally construction activities have the potential to generate noise. Construction will be limited to normal working hours to minimize the disturbance that construction-related noise could cause. The proposed development is adjacent to an existing operating mine and National Highway and the environment is not considered extremely noise sensitive. No significant Noise will be generated during the operational phase of the development.

13. WATER USE

Please indicate the source(s) of water that will be used for the activity by ticking the appropriate box(es):

<input checked="" type="checkbox"/> Municipal	<input type="checkbox"/> Water board	<input type="checkbox"/> Groundwater	<input type="checkbox"/> River, stream, dam or lake	<input checked="" type="checkbox"/> Other	<input type="checkbox"/> The activity will not use water
---	--------------------------------------	--------------------------------------	---	---	--

If water is to be extracted from groundwater, river, stream, dam, lake or any other natural feature, please indicate the volume that will be extracted per month:

Does the activity require a water use authorisation (general authorisation or water use license) from the Department of Water Affairs?

If YES, please provide proof that the application has been submitted to the Department of Water Affairs.

litres	
<input type="checkbox"/> YES	<input checked="" type="checkbox"/> NO

Very little water will be present on site: Potable water for construction workers will be provided. Some water may be required for mixing of concrete and general construction activities. This will be sourced either from the Mine or from the Local Municipality.

14. ENERGY EFFICIENCY

Describe the design measures, if any, which have been taken to ensure that the activity is energy efficient:

None

Describe how alternative energy sources have been taken into account or been built into the design of the activity, if any:

None

SECTION B: SITE/AREA/PROPERTY DESCRIPTION

Important notes:

1. For linear activities (pipelines, etc) as well as activities that cover very large sites, it may be necessary to complete this section for each part of the site that has a significantly different environment. In such cases please complete copies of Section B and indicate the area, which is covered by each copy No. on the Site Plan.

Section B Copy No. (e.g. A): 1

2. Paragraphs 1 - 6 below must be completed for each alternative.

3. Has a specialist been consulted to assist with the completion of this section? ~~YES~~ NO

If YES, please complete the form entitled "Details of specialist and declaration of interest" for each specialist thus appointed and attach it in Appendix I. All specialist reports must be contained in Appendix D.

Property description/physical address:

Province	Northern Cape
District Municipality	John Taolo Gaetsewe District Municipality
Local Municipality	Gamagara Local Municipality
Ward Number(s)	6
Farm name and number	Kathu
Portion number	Sekgame 461
SG Code	Re

Where a large number of properties are involved (e.g. linear activities), please attach a full list to this application including the same information as indicated above.

Current land-use zoning as per local municipality IDP/records:

The site is located next to the N14 Highway in the servitude. The property falls within the Sishen Mine's Mining Right Area.

In instances where there is more than one current land-use zoning, please attach a list of current land use zonings that also indicate which portions each use pertains to, to this application.

Is a change of land-use or a consent use application required? YES ~~NO~~

BASIC ASSESSMENT REPORT

1. GRADIENT OF THE SITE

Indicate the general gradient of the site.

Alternative S1:

Flat	1:50 – 1:20	1:20 – 1:15	1:15 – 1:10	1:10 – 1:7,5	1:7,5 – 1:5	Steeper than 1:5
-----------------	-------------	-------------	-------------	--------------	-------------	------------------

Alternative S2 (if any):

Flat	1:50 – 1:20	1:20 – 1:15	1:15 – 1:10	1:10 – 1:7,5	1:7,5 – 1:5	Steeper than 1:5
-----------------	-------------	-------------	-------------	--------------	-------------	------------------

Alternative S3 (if any):

Flat	1:50 – 1:20	1:20 – 1:15	1:15 – 1:10	1:10 – 1:7,5	1:7,5 – 1:5	Steeper than 1:5
-----------------	-------------	-------------	-------------	--------------	-------------	------------------

2. LOCATION IN LANDSCAPE

Indicate the landform(s) that best describes the site:

2.1 Ridgeline	<input type="checkbox"/>	2.4 Closed valley	<input type="checkbox"/>	2.7 Undulating plain / low hills	<input checked="" type="checkbox"/>
2.2 Plateau	<input type="checkbox"/>	2.5 Open valley	<input type="checkbox"/>	2.8 Dune	<input type="checkbox"/>
2.3 Side slope of hill/mountain	<input type="checkbox"/>	2.6 Plain	<input checked="" type="checkbox"/>	2.9 Seafront	<input type="checkbox"/>
2.10 At sea	<input type="checkbox"/>				

3. GROUNDWATER, SOIL AND GEOLOGICAL STABILITY OF THE SITE

Is the site(s) located on any of the following?

	Alternative S1:		Alternative S2 (if any):		Alternative S3 (if any):	
Shallow water table (less than 1.5m deep)	YES	NO	YES	NO	YES	NO
Dolomite, sinkhole or doline areas	YES	NO	YES	NO	YES	NO
Seasonally wet soils (often close to water bodies)	YES	NO	YES	NO	YES	NO
Unstable rocky slopes or steep slopes with loose soil	YES	NO	YES	NO	YES	NO
Dispersive soils (soils that dissolve in water)	YES	NO	YES	NO	YES	NO
Soils with high clay content (clay fraction more than 40%)	YES	NO	YES	NO	YES	NO
Any other unstable soil or geological feature	YES	NO	YES	NO	YES	NO
An area sensitive to erosion	YES	NO	YES	NO	YES	NO

If you are unsure about any of the above or if you are concerned that any of the above aspects may be an issue of concern in the application, an appropriate specialist should be appointed to assist in the completion of this section. Information in respect of the above will often be available as part of the project information or at the planning sections of local authorities. Where it exists, the 1:50 000 scale Regional Geotechnical Maps prepared by the Council for Geo Science may also be consulted.

BASIC ASSESSMENT REPORT

4. GROUNDCOVER

Indicate the types of groundcover present on the site. The location of all identified rare or endangered species or other elements should be accurately indicated on the site plan(s).

Natural veld in good condition^E	Natural veld with scattered aliens^E	Natural veld with heavy alien infestation ^E	Veld dominated by alien species ^E	Gardens
Sport field	Cultivated land	Paved surface	Building or other structure	Bare soil

If any of the boxes marked with an “E” is ticked, please consult an appropriate specialist to assist in the completion of this section if the environmental assessment practitioner doesn’t have the necessary expertise.

5. SURFACE WATER

Indicate the surface water present on and or adjacent to the site and alternative sites?

Perennial River	YES	NO	UNSURE
Non-Perennial River	YES	NO	UNSURE
Permanent Wetland	YES	NO	UNSURE
Seasonal Wetland	YES	NO	UNSURE
Artificial Wetland	YES	NO	UNSURE
Estuarine / Lagoonal wetland	YES	NO	UNSURE

If any of the boxes marked YES or UNSURE is ticked, please provide a description of the relevant watercourse.

Alternative three supposes the Switching yard construction further south than the preferred alternative, closer to the Gamagara River, which is the closest water body to the site.

6. LAND USE CHARACTER OF SURROUNDING AREA

Indicate land uses and/or prominent features that currently occur within a 500m radius of the site and give description of how this influences the application or may be impacted upon by the application:

Natural area	Dam or reservoir	Polo fields
Low density residential	Hospital/medical centre	Filling station ^H
Medium density residential	School	Landfill or waste treatment site
High density residential	Tertiary education facility	Plantation
Informal residential ^A	Church	Agriculture
Retail commercial & warehousing	Old age home	River, stream or wetland
Light industrial	Sewage treatment plant ^A	Nature conservation area
Medium industrial ^{AN}	Train station or shunting yard ^N	Mountain, koppie or ridge
Heavy industrial ^{AN}	Railway line ^N	Museum
Power station	Major road (4 lanes or more) ^N	Historical building
Office/consulting room	Airport ^N	Protected Area

BASIC ASSESSMENT REPORT

Military or police base/station/compound	Harbour	Graveyard
Spoil heap or slimes dam ^A	Sport facilities	Archaeological site
Quarry, sand or borrow pit	Golf course	Other land uses (describe)
The existing Ferrum Switching Station is located at the northern most end of the proposed project. The Shooting Range Servitude is located to the west of the project.		

If any of the boxes marked with an "N" are ticked, how will this impact / be impacted upon by the proposed activity? Specify and explain:

This section of the N14 caters for only one lane of traffic in each direction. It is however still considered a major road as it is the most significant road in the area.
The activity will have no impact on the N14 Highway as the development site is adjacent to the highway in the servitude.

If any of the boxes marked with an "An" are ticked, how will this impact / be impacted upon by the proposed activity? Specify and explain:

The proposed project is located within the boundary of the existing Sishen Mining Right Area. The proposed project infrastructure is however almost 2 km from the nearest mining activities. The existing Sishen Slimes Dam is located approximately 1.5 km South West of the existing Ferrum Substation, and approximately 1.6 km to the west of the proposed electricity infrastructure at the closest point. These existing mining related activities will therefore not be affected by the proposed project due to distance. The proposed project will however facilitate the ongoing activities at Sishen Mine requiring electricity.

If any of the boxes marked with an "H" are ticked, how will this impact / be impacted upon by the proposed activity? Specify and explain:

N/A

Does the proposed site (including any alternative sites) fall within any of the following:

Critical Biodiversity Area (as per provincial conservation plan)	YES	NO
Core area of a protected area?	YES	NO
Buffer area of a protected area?	YES	NO
Planned expansion area of an existing protected area?	YES	NO
Existing offset area associated with a previous Environmental Authorisation?	YES	NO
Buffer area of the SKA?	YES	NO

If the answer to any of these questions was YES, a map indicating the affected area must be included in Appendix A.

7. CULTURAL/HISTORICAL FEATURES

Are there any signs of culturally or historically significant elements, as defined in section 2 of the National Heritage Resources Act, 1999, (Act No. 25 of 1999), including Archaeological or paleontological sites, on or close (within 20m) to the site? If YES, explain:	YES	NO
	Uncertain	

BASIC ASSESSMENT REPORT

A survey of the site was carried out during September 2014 by Mr N Kruger. The Phase 1 Heritage Impact Assessment identified the following:

- Site EXIGO-SG461-SA01: S27.76450 E23.06762 (Low density MSA lithic scatter)

A low density Middle Stone Age (MSA) scatter was identified along the proposed electricity distribution line in association with a shallow quarry, directly adjacent to the N14 road. The area has been significantly altered as a result of digging at the quarry

The occurrence is of limited scientific value within its local site context due to the general loss of context and site integrity for the artefacts at the quarry, and the low density of diagnostic formal tools. However, the site is situated within (and possibly part of) the significant larger Kathu Stone Age Complex and on a regional scale it might be of importance.

- Site EXIGO-SG461-SA02: S27.77174 E23.06743 (Low density MSA lithic scatter)
- Site EXIGO-SG461-SA03: S27.77589 E23.06703 (Low density MSA lithic scatter)

A larger scatter of MSA material was documented towards the southern offset of the proposed electricity distribution line, as well as in the eastern sector of the proposed Sekgame switching yard site. Similar to related Stone Age occurrences in the area, these MSA scatters occur mainly as a single horizon within a shallow, decomposed calcrete formation, where precipitation and groundwater have exposed the stone tools.

The Stone Age representations at the site are of interest due to the presence of formal stone tools, as well as its position within the larger Kathu Complex. A specialist analysis of lithics from the sites will provide an understanding of the development and spread of the early MSA in the Northern Cape and Karoo areas.

If uncertain, conduct a specialist investigation by a recognised specialist in the field (archaeology or palaeontology) to establish whether there is such a feature(s) present on or close to the site. Briefly explain the findings of the specialist:

See above and also refer to the Specialist Report contained in Appendix D.

A Phase 2 HIA will have to be conducted on the MSA Site, if the layout cannot be at all shifted to avoid this site entirely.

Will any building or structure older than 60 years be affected in any way?

YES	NO
YES	NO

Is it necessary to apply for a permit in terms of the National Heritage Resources Act, 1999 (Act 25 of 1999)?

If YES, please provide proof that this permit application has been submitted to SAHRA or the relevant provincial authority.

A Phase 2 HIA will have to be conducted on the MSA Site, if the layout cannot be at all shifted to avoid this site entirely.

8. SOCIO-ECONOMIC CHARACTER

a) Local Municipality

Please provide details on the socio-economic character of the local municipality in which the proposed site(s) are situated.

Level of unemployment:

The current unemployment rate in the Gamagara Municipality is 17.7% according to Stats SA. Youth unemployment rate is higher at 22.4%

BASIC ASSESSMENT REPORT

Economic profile of local municipality:

“The single largest factor that has guided the development of the Gamagara area is the iron ore mine at Sishen. Not only does the mine provide jobs to thousands of people, but it was also the reason for the establishment of the town of Kathu.” (http://beta2.statssa.gov.za/?page_id=993&id=gamagara-municipality)

Of the households in the municipality, 87,6% have access to flush toilets, 97% have access to piped water and 87,9% Use electricity for lighting.

Average Household income is presented in the following Table:

Income	Percentage
None income	10,1%
R1 - R4,800	1,9%
R4,801 - R9,600	3,9%
R9,601 - R19,600	11,2%
R19,601 - R38,200	16,8%
R38,201 - R76,4000	16,6%
R76,401 - R153,800	15,1%
R153,801 - R307,600	12,5%
R307,601 - R614,400	8,3%
R614,001 - R1,228,800	2,7%
R1,228,801 - R2,457,600	0,6%
R2,457,601+	0,3%

(from Statistics South Africa at http://beta2.statssa.gov.za/?page_id=993&id=gamagara-municipality)

Level of education:

Group	Percentage
No Schooling	4,2%
Some Primary	40,9%
Completed Primary	6,3%
Some Secondary	30,9%
Completed Secondary	13,5%
Higher Education	1,5%
Not Applicable	2,6%

(from Statistics South Africa at http://beta2.statssa.gov.za/?page_id=993&id=gamagara-municipality)

b) Socio-economic value of the activity

What is the expected capital value of the activity on completion?

What is the expected yearly income that will be generated by or as a result of the activity?

Will the activity contribute to service infrastructure?

Is the activity a public amenity?

How many new employment opportunities will be created in the development and construction phase of the activity/ies?

What is the expected value of the employment opportunities during the development and construction phase?

What percentage of this will accrue to previously disadvantaged individuals?

How many permanent new employment opportunities will be created during the operational phase of the activity?

What is the expected current value of the employment opportunities during the first 10 years?

What percentage of this will accrue to previously disadvantaged individuals?

R 21 mil
R 0
YES NO
YES NO
28
R 9 mil. pa
33 %
3
R 10 mil
33 %

9. BIODIVERSITY

Please note: The Department may request specialist input/studies depending on the nature of the biodiversity occurring on the site and potential impact(s) of the proposed activity/ies. To assist with the identification of the biodiversity occurring on site and the ecosystem status consult <http://bgis.sanbi.org> or BGIShelp@sanbi.org. Information is also available on compact disc (cd) from the Biodiversity-GIS Unit, Ph (021) 799 8698. This information may be updated from time to time and it is the applicant/ EAP's responsibility to ensure that the latest version is used. A map of the relevant biodiversity information (including an indication of the habitat conditions as per (b) below) and must be provided as an overlay map to the property/site plan as Appendix D to this report.

- a) **Indicate the applicable biodiversity planning categories of all areas on site and indicate the reason(s) provided in the biodiversity plan for the selection of the specific area as part of the specific category)**

Systematic Biodiversity Planning Category				If CBA or ESA, indicate the reason(s) for its selection in biodiversity plan
Critical Biodiversity Area (CBA)	Ecological Support Area (ESA)	Other Natural Area (ONA)	No Natural Area Remaining (NNR)	

- b) **Indicate and describe the habitat condition on site**

Habitat Condition	Percentage of habitat condition class (adding up to 100%)	Description and additional Comments and Observations (including additional insight into condition, e.g. poor land management practises, presence of quarries, grazing, harvesting regimes etc).
Natural	90%	Please refer to the Specialist Report – Ecology, included in Appendix D, and to the Vegetation Summary and Map Provided hereunder.
Near Natural (includes areas with low to moderate level of alien invasive plants)	10%	
Degraded (includes areas heavily invaded by alien plants)	%	
Transformed (includes cultivation, dams, urban, plantation, roads, etc)	%	



BASIC ASSESSMENT REPORT

c) Complete the table to indicate:



- (i) the type of vegetation, including its ecosystem status, present on the site; and
- (ii) whether an aquatic ecosystem is present on site.

Terrestrial Ecosystems		Aquatic Ecosystems								
Ecosystem threat status as per the National Environmental Management: Biodiversity Act (Act No. 10 of 2004)	Critical	Wetland (including rivers, depressions, channelled and unchannelled wetlands, flats, seeps pans, and artificial wetlands)			Estuary		Coastline			
	Endangered									
	Vulnerable									
	Least Threatened	YES	NO	UNSURE	YES	NO	YES	NO		



d) Please provide a description of the vegetation type and/or aquatic ecosystem present on site, including any important biodiversity features/information identified on site (e.g. threatened species and special habitats)

<i>Tarchonanthus camphoratus</i> shrubveld:			
	<i>Open variation</i>		<i>Mixed Tarchonanthus – Ziziphus variation</i>
State of the vegetation:	Natural state		Natural state
Conservation priority	Medium		Medium
Characteristics	Very open shrubveld dominated by camphor bush (vaalbos) on deep Kalahari sands.		Medium dense to open shrubveld dominated by camphor bush, buffalo thorn and <i>Searsia ciliata</i> on medium depth Kalahari sands. Calcrete exposed in the surface in some instances (pans).
Density of woody layer	Trees: <1% (avg. height: 3-6m)		Trees: <1% (avg. height: 3-6m)
	Shrubs: 10-15% (avg. height: 1-2m)		Shrubs: 15-20% (avg. height: 1-2m)
Density of herbaceous layer	Grasses: 60-70% (avg. height: 0.8-1.2m)		Grasses: 40-50% (avg. height: 0.8-1.2m)
	Forbs: 2-5 (avg. height: 0.8m)		Forbs: 2-5 (avg. height: 0.8m)
Sensitivity	Medium – indigenous woodland with a widespread status		Medium – indigenous woodland with a widespread status
Protected / Red data species	None observed		None observed
Protected tree species	None observed		Acacia erioloba
			
	Open <i>Tarchonanthus</i> shrubveld		Mixed <i>Tarchonanthus</i> – <i>Ziziphus</i> variation
<i>Acacia mellifera</i> – <i>Tarchonanthus camphoratus</i> calcrete ridges;			
	Natural variation		Degraded variation (quarry)

BASIC ASSESSMENT REPORT

State of the vegetation:	Natural woodland	Degraded bushveld with alien species and exotic weeds
Conservation priority	Medium	Low
Characteristics	This vegetation unit is characterized by a woody layer mostly dominated by low shrubs that form an open to medium dense structure. The woody species is dominated by black thorn and camphor bush shrubs throughout its distribution in the local context. Substrate is deep, sandy-loam soils typical of the Kathu Bushveld vegetation type.	This degraded quarry has been completely degraded and represents bare ground with exotic aliens, pioneer grasses and a few scattered woody species.
Density of woody layer	Trees: 5-10% (avg. height: 3-6m)	Trees: <1% (avg. height: 3-6m)
	Shrubs: 15-30% (avg. height: 1-2m)	Shrubs: 10% (avg. height: 1-2m)
Density of herbaceous layer	Grasses: 40-50% (avg. height: 0.8-1.2m)	Grasses: 20-30% (avg. height: 0.8-1.2m)
	Forbs: 2-5 (avg. height: 0.8m)	Forbs: 2-5 (avg. height: 0.8m)
Sensitivity	Medium – indigenous woodland with a widespread status	Low - degraded land in a modified state
Protected / Red data species	None observed	None observed
Protected tree species	Acacia erioloba	Acacia erioloba
		
	Natural variation of the Acacia mellifera – Tarchonanthus camphoratus calcrete ridges	Degraded quarry that was mined for gravel to build the N14 road
Open Acacia erioloba – Grewia flava woodland;		
State of the vegetation:	Natural veld	
Conservation priority	Medium	
Characteristics	This vegetation unit is characterized by young camel thorn trees and velvet raisin bush, while the grass layer is dominated by <i>Stipagrostis uniplumis</i>	
Density of woody layer	Trees: 5-10% (avg. height: 3-6m)	
	Shrubs: 1-2% (avg. height: 1-2m)	
Density of herbaceous layer	Grasses: 40-50% (avg. height: 0.8-1.2m)	
	Forbs: 2-5 (avg. height: 0.8m)	
Sensitivity	Medium – indigenous woodland with a widespread status	
Red data species	None observed.	
Protected tree species	Acacia erioloba	

BASIC ASSESSMENT REPORT

		
<p>Acacia erioloba – Grewia flava woodland on the site of the proposed Sekgame switching yard</p> <p>Open Tarchonanthus – Eragrostis pallens grassland;</p>		
State of the vegetation:	Slightly degraded veld	
Conservation priority	Medium-low	
Characteristics	This vegetation unit is characterized by tall grassland with scattered camphor bush shrubs. Wood harvesting occurred in the area many years ago.	
Density of woody layer	Trees: <1% (avg. height: 3-6m)	
	Shrubs: 1-2% (avg. height: 1-2m)	
Density of herbaceous layer	Grasses: 70-80% (avg. height: 0.8-1.2m)	
	Forbs: <1% (avg. height: 0.8m)	
Sensitivity	Medium-low – grassland in a slightly degraded state	
Red data species	None observed.	
Protected tree species	None observed.	
		
<p>Open Tarchonanthus – Eragrostis pallens grassland</p>		

BASIC ASSESSMENT REPORT

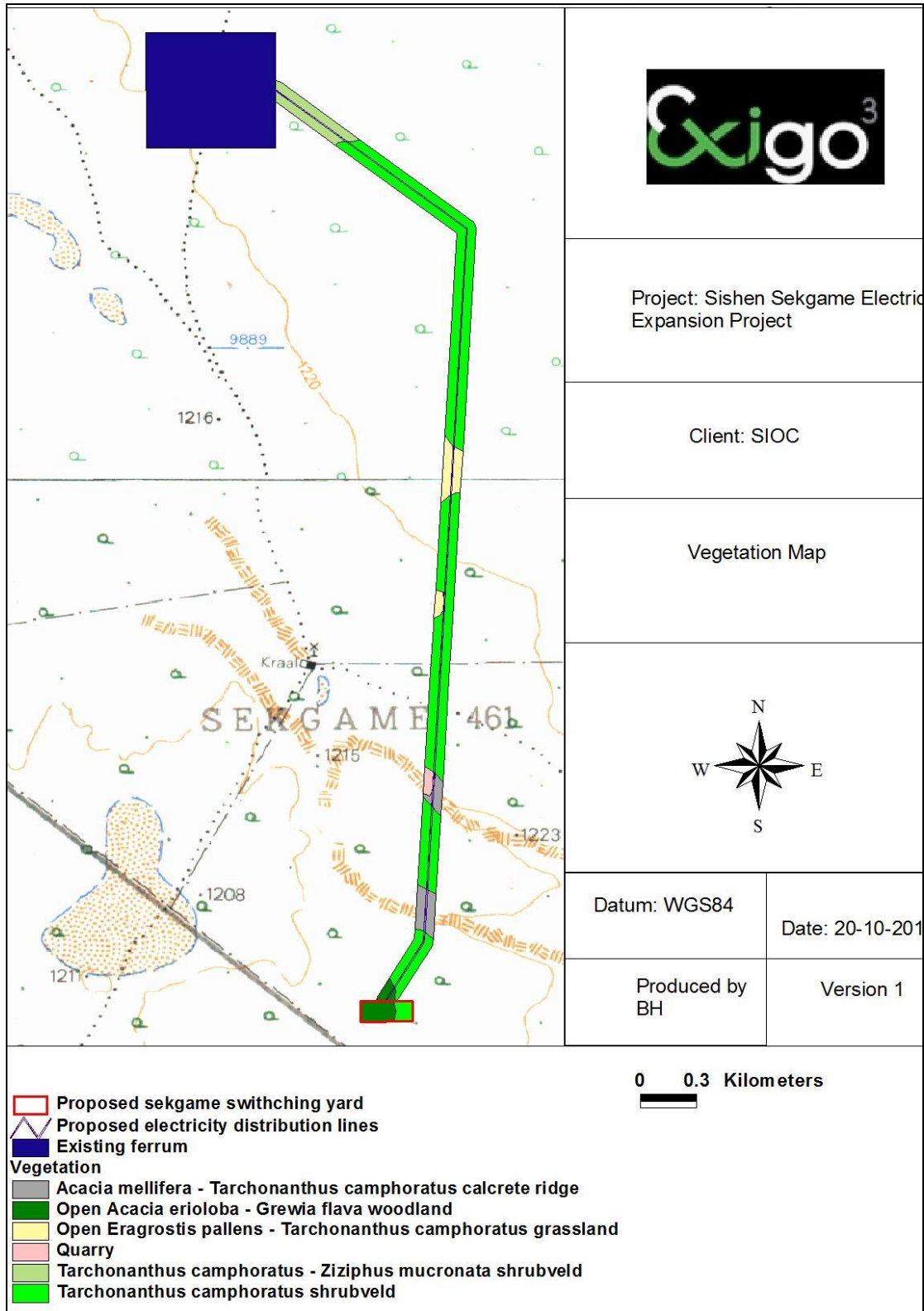

Figure 1: Vegetation Map

SECTION C: PUBLIC PARTICIPATION

1. ADVERTISEMENT AND NOTICE

Publication name	Kathu Gazette	
Date published	27 February 2015	
Site notice position	Latitude	Longitude
	27°45'29.65"S	23° 4'5.46"E
Date placed	27 February 2015	

Include proof of the placement of the relevant advertisements and notices in Appendix E1.

2. DETERMINATION OF APPROPRIATE MEASURES

Provide details of the measures taken to include all potential I&APs as required by Regulation 41(2)(e) and 41(6) of GN 733.

Key stakeholders (other than organs of state) identified in terms of Regulation 41(2)(b) of GN 733

Title, Name and Surname	Affiliation/ key stakeholder status	Contact details (tel number or e-mail address)
Alex Mostert	Assmang Ltd	alexm@assmang.co.za
Tania Anderson	WESSA: NC Conservation	spothil@gmail.com
Badie Badenhorst	Agri Northern Cape	ncagric@worldonline.co.za
Judi Bolwez	Kathu Gazette	editor@kathugazette.co.za
Johan Botha	Boegoeberg Water User Association	ceowua@boegoebergwater.co.za
Willie Bruwer	Orange Vaal Water User Association	aqua@douglas.co.za
Stephanie Cornelissen	Wright 538, ptn 0	wright@polka.co.za
Andre de Villiers	Reverend of NG Kerk, Kathu	andre@ngkathu.co.za
De Villiers	Water Users Association & Octagonal Development CC.	erika@octagonal.co.za;
Denise Eilers	Gamagara High School	gamagara@h@gmail.com
Suzanne Erasmus	WESSA Northern Cape c/o McGregor Museum	wessanc@yahoo.com ; wessanc.conservation@yahoo.com
Collin Fortune	McGregor Museum	cfortune@museumsnc.co.za
Hennie / Hester Magrieta / Dawid Hermanus Fourie	Bishopswood ptn 2	hennie@electri-city.co.za
Nico	Fourie	ngc@mtnloaded.co.za
Gerhard Leibbrandt	Chief Administrative Official Transnet Freight Rail (Infrastructure)	Gerhard.Leibbrandt@transnet.net
Louis Hauman	Agri Kuruman	louis@soetvlakte.co.za
Jaap Hoffman	Parsons 564, ptn 4	jaap.hoffman@angloamerican.com
Shawn Johnston	Process Specialist, Sustainable Futures ZA	swjohnston@mweb.co.za
Mr D Maleke	Sedibeng Water: Communication Officer	dmaleke@sedibengwater.co.za
Abrie Maritz	Curtis Boerdery CC	maritzsiviel@vodamail.co.za
Alfred Markram	Moria Boerdery cc	amarkram@tramirloc.co.za / amarkram@gmail.com
Clive Moses	National Development Agency	clivem@nda.org.za
Mr Livhuwani Wilson Ndou	Transnet Freight Rail – Risk	Livhuwani.Ndou@transnet.net

BASIC ASSESSMENT REPORT

	Department: Environmental Specialist	
Kallie Page	NG Kerk	kallie.page@angloamerican.com
Annette Smit	Sanyati Guest House	annette@sanyatibb.co.za
André Swart	DALR & RD	aswart@agri.ncape.gov.za
Andrea van Gensen	Eskom Environmental Officer	vgenseal@eskom.co.za
Albertus Viljoen	Tshiping Water user Association	info@tshiping.co.za

Include proof that the key stakeholder received written notification of the proposed activities as Appendix E2. This proof may include any of the following:

- e-mail delivery reports;
- registered mail receipts;
- courier waybills;
- signed acknowledgements of receipt; and/or
- or any other proof as agreed upon by the competent authority.

3. ISSUES RAISED BY INTERESTED AND AFFECTED PARTIES

Summary of main issues raised by I&APs	Summary of response from EAP
<p>This is the Draft Basic Assessment Report which is made available to relevant stakeholders and Interested and Affected Parties (I&APs) for comment. The comment period is 40 days. Once comments have been received, this Draft BAR will be duly updated and the Final Basic Assessment Report, which will include summaries of and copies of all comments received, will be submitted to the I&APs for another review period (30 days) and to the DENC for consideration.</p>	

4. COMMENTS AND RESPONSE REPORT

The practitioner must record all comments received from I&APs and respond to each comment before the Draft BAR is submitted. The comments and responses must be captured in a comments and response report as prescribed in the EIA regulations and be attached to the Final BAR as Appendix E3.

5. AUTHORITY PARTICIPATION

Authorities and organs of state identified as key stakeholders:

Authority/Organ of State	Contact person (Title, Name and Surname)	Tel No	Fax No	e-mail	Postal address
Department of Water Affairs	Abe Abrahams			AbrahamsA@dwa.gov.za	P Bag X 313 Pretoria 0001
Gamagara Municipality - town planning officer	Johan Burger			johannb@gamagara.co.za	
South African	Mariagrazia			mgalimberty@sahra.org.za	

BASIC ASSESSMENT REPORT

Heritage Resource Association	Galimberti				
Gamagara Local Municipality, Municipal Manager	Cornelius Joachim	053 723 2261	053 723 2221	corneliusj@gamagara.co.za	PO Box 1001, Kathu, 8446
Northern Cape Department of Environmental Affairs and Nature Conservation	Sylvia Lucas	053 832 1022	053 832 1026	slucas@ncpg.gov.za	Private Bag X6010, Kimberly, 8300
Department of Mineral Resources	Ncedisa Mahala			Ncedisa.Mahala@dmr.gov.za	
Kuruman District Municipality Health Officer	Mrs V Manong	053 712 0775	053 712 0656	vmanong@kur.ncape.gov.za	Private Bag X910, Kuruman, 8460
Department of Forestry	Jacoline Mans	054 338 5800	054 334 0205	JacolineMa@daff.gov.za	Private Bax X5912 Uppington 8800
Economic Development Specialist and Advisor to National Government - Pretoria.	Dr FM Lucky Mathebuila			mathebula@yebo.co.za	
Development Planning, Provincial Support.	Ms J Meyer	0538025108	0866200426	jmeyer@ncpg.gov.za	Office of the Premier, Templar Building, 6th Floor, Kimberley, 8530
Department of Agriculture, Land Reform and Rural Development	Vijoen Mothibi	053 838 9118	053 831 3635	cfortune@agri.ncape.gov.za	
Moshaweng Local Municipality	Mr O Phiri	053 773 6001		tmtlhoaele@yahoo.com	
Gamagara Local Municipality (Mayor)	Molodi Rakoi	053 723 2261	053 723 2021	mayorg@gamagara.co.za	PO Box 1001, Kathu, 8446
South African Heritage Resource Association	Andrew Timothy	053 831 2537	053 833 1435	atimothy@sahra.org.za	PO Box 1930, Kimberly, 8300
Department of Agriculture, Land Reform and Rural Development	Felicity van Heerden	053-8397856	086-7296363	FvanHeerden@ncpg.gov.za	
Khara Hais Municipality	Manager			manager@kharahais.co.za	

Include proof that the Authorities and Organs of State received written notification of the proposed activities as appendix E4.

In the case of renewable energy projects, Eskom and the SKA Project Office must be included in the list of Organs of State.

6. CONSULTATION WITH OTHER STAKEHOLDERS

Note that, for any activities (linear or other) where deviation from the public participation requirements may be appropriate, the person conducting the public participation process may deviate from the requirements of that sub-regulation to the extent and in the manner as may be agreed to by the competent authority.

Proof of any such agreement must be provided, where applicable. Application for any deviation from the regulations relating to the public participation process must be submitted prior to the commencement of the public participation process.

A list of registered I&APs must be included as appendix E5.

Copies of any correspondence and minutes of any meetings held must be included in Appendix E6.

SECTION D: IMPACT ASSESSMENT

The assessment of impacts must adhere to the minimum requirements in the EIA Regulations, 2014 and should take applicable official guidelines into account. The issues raised by interested and affected parties should also be addressed in the assessment of impacts.

1. IMPACTS THAT MAY RESULT FROM THE PLANNING AND DESIGN, CONSTRUCTION, OPERATIONAL, DECOMMISSIONING AND CLOSURE PHASES AS WELL AS PROPOSED MANAGEMENT OF IDENTIFIED IMPACTS AND PROPOSED MITIGATION MEASURES

Provide a summary and anticipated significance of the potential direct, indirect and cumulative impacts that are likely to occur as a result of the planning and design phase, construction phase, operational phase, decommissioning and closure phase, including impacts relating to the choice of site/activity/technology alternatives as well as the mitigation measures that may eliminate or reduce the potential impacts listed. This impact assessment must be applied to all the identified alternatives to the activities identified in Section A(2) of this report.

Activity	Impact summary	Significance	Proposed mitigation
Alternative 1 (preferred alternative) (Same for Alternative 2 and 3)			
Presence of the Switching Yard and electricity distribution lines	Direct impacts:		
	Visual Intrusion	Low	None required – visual landscape has already been significantly altered and the infrastructure is in keeping with the surroundings
	Erosion due to exposed soils	Low	Exposed soils will be covered where possible and amount of disturbance to be minimized
	Dust due to exposed soils (Air quality deterioration)	Low	Stringent erosion and dust control practices will be implemented. A speed limit (max 40km/h) will be enforced on all dirt roads
	Potential pollution from spillages from vehicles and materials on site	Low	Appropriate waste management practices will be implemented; Storage of materials will be so as to prevent spillages; training will be provided in management of accidental spillages (use of spill kits); Regular vehicle maintenance will ensure vehicle spillages are avoided; drip trays to be implemented where relevant.
Habitat destruction due to vegetation clearance	Low	Vegetation clearance to be kept to a minimum – clear demarcation of development footprint and no-go-areas. Permits will be obtained where removal of protected species cannot be avoided. Rehabilitation will be prioritized and will occur concurrently with construction. An ECO will be appointed for the duration of the construction	

BASIC ASSESSMENT REPORT

Activity	Impact summary	Significance	Proposed mitigation
			phase.
	Habitat fragmentation due to clearance of vegetation	Low	Existing facilities will be used as far as possible to limit amount of new disturbance. Protective buffers implemented around sensitive features. No-Go Areas to be clearly demarcated
	Spread of alien invasive species due to movement of personnel and vehicles	Low	Strict control over materials brought to site. Alien invasive monitoring and management programme to be implemented. Disturbed areas will be rehabilitated immediately.
	Avifauna electrocutions or collisions due to the presence of the power-line	Low - Negligible	Avian safe facilities will be provided. Lines will also be marked with anti-collision devices as per the Eskom Guidelines.
	Impact on Heritage Resources	Moderate - Low	Heritage sites should be avoided where possible. If site SG461-SA02 and SG461-SA03 cannot be avoided then a Phase 2 HIA will be done and a destruction permit obtained prior to any disturbance to these sites taking place.
	Negative effects on flora and fauna due to presence of humans on site for construction	Low	No staff will be accommodated on site. Local labour to be used as far as possible. Proper firebreaks will be maintained. No fires will be allowed on site. No-Go Areas will be strictly implemented. Proper waste management practices will be implemented and environmental education / training provided.
No-go option			
	Direct impacts:		
	Shortage of available electricity distribution infrastructure at Mines in the area, especially at Sishen Mine.	High	
	No additional Employment opportunities created during the construction phase	Moderate	
	Indirect impacts:		
	Limitations on expansion projects at Sishen resulting in loss of socio-economic opportunities from expansion projects	High	
	Cumulative impacts:		
	<p>The implementation of the No-Go alternative (or the no-development option) would mean that the site will be left in its current state. The status quo of the site would thus be maintained, and none of the identified potential negative impacts would be realized. However, none of the project benefits would be realized either and the Sishen Mine and other Mine's in the area are likely to experience shortages in electricity rendering them unable to continue with mining and mining expansion projects that require electricity. Thus the direct impacts of implementing the no-development option lies primarily in the employment opportunities associated with the construction and maintenance of the infrastructure that would not be realized. Cumulatively, not implementing the proposed</p>		

BASIC ASSESSMENT REPORT

Activity	Impact summary	Significance	Proposed mitigation
	project could have significant negative effects on surrounding industries (including Sishen Mine) and all of the Socio-economic benefits associated with those projects requiring electricity.		

A complete impact assessment in terms of Regulation 19(3) of GN 733 must be included as Appendix F.

2. ENVIRONMENTAL IMPACT STATEMENT

Taking the assessment of potential impacts into account, please provide an environmental impact statement that summarises the impact that the proposed activity and its alternatives may have on the environment after the management and mitigation of impacts have been taken into account, with specific reference to types of impact, duration of impacts, likelihood of potential impacts actually occurring and the significance of impacts.

Alternative A (preferred alternative)

The preferred alternative involves the development of the electricity distribution lines from the existing Ferrum Substation in the North of the study area, southwards between the existing Shooting Range servitude and the N14 highway, up to the proposed Sekgame Switching Station which is to comprise a footprint area of 250 meters long and 100 meters wide, approximately 110 meters west from the N14.

The proposed development of this infrastructure will inevitably result in some direct habitat destruction and habitat fragmentation. The development footprint is however comparatively small and it is anticipated that any protected trees occurring on the site can be effectively retained. The specialist report (See AppendixD) found that the impacts, after the implementation of mitigation measures, will have a low significance.

The electricity distribution lines and Switching Yard Sites contain Heritage Resources in the form of Stone Age artefacts. It is proposed that the infrastructure be re-aligned to avoid these sites and a 20 meter buffer around them. If this is not possible, a Phase 2 Heritage Impact Assessment will have to be conducted to document the sites, and a destruction permit from SAHRA will have to be obtained prior to construction commencing. With the implementation of these mitigation measures, the anticipated impacts from the project on these resources will be negligible.

Construction projects always carry a risk of pollution occurring due to spillages of material associated with construction, due to increased erosion potential and risk of spread of alien invasive species from disturbed sites, and due to increased potential for dust pollution. These impacts will mostly be limited to the construction phase of the project although some risk remains during the operational phase associated with maintenance activities. With the implementation of appropriate mitigation measures, these impacts can be effectively managed to low-negligible levels.

The presence of the proposed electricity distribution infrastructure could pose a risk to avifauna (birds) in terms of potential for electrocution, and collisions. With the implementation of mitigation measures (aimed at preventing electrocution and collisions from occurring due to appropriate, avifauna-safe designs of the infrastructure) these impacts are considered low – negligible.

Alternative B

This alternative considers the position of the Sekgame Switching Station on the existing Shooting Range servitude. This Alternative will result in comparable impacts as the preferred alternative, however implementation of this alternative is not feasible due to potential for interference with the Shooting Range servitude.

Alternative C

This alternative considered extending the proposed electricity distribution infrastructure to the South. The impacts associated with this alternative would be the same as for the preferred alternative, and possible more significant (the ecology and archaeology investigations did not include this extended footprint and

thus the precautionary principle would dictate that insufficient information is available to adequately assess the impacts on the extended footprint area and that the impacts must therefore be considered significant).

No-go alternative (compulsory)

The implementation of the No-Go alternative (or the no-development option) would mean that the site will be left in its current state. The status quo of the site would thus be maintained, and none of the identified potential impacts would be realized. However, none of the project benefits would be realized either and the Sishen Mine and other Mine's in the area are likely to experience shortages in electricity rendering them unable to continue with mining and mining expansion projects that require electricity.

Thus the direct impacts of implementing the no-development option lies primarily in the employment opportunities associated with the construction and maintenance of the infrastructure that would not be realized. Cumulatively, not implementing the proposed project could have significant negative effects on surrounding industries (including Sishen Mine) and all of the Socio-economic benefits associated with those projects requiring electricity.

BASIC ASSESSMENT REPORT

Section E. Recommendation of practitioner

Is the information contained in this report and the documentation attached hereto sufficient to make a decision in respect of the activity applied for (in the view of the environmental assessment practitioner)?

YES	NO
-----	---------------

If "NO", indicate the aspects that should be assessed further as part of a Scoping and EIA process before a decision can be made (list the aspects that require further assessment).

Please note that this is the Draft Basic Assessment Report and that no decision should be made in respect of the application until the results of the Public Participation Process have been incorporated, including the relevant stakeholders, Interested and Affected Parties, and commenting Authorities' comment on this project.

If "YES", please list any recommended conditions, including mitigation measures that should be considered for inclusion in any authorisation that may be granted by the competent authority in respect of the application.

The following measures are included in the EMPr and will be essential in ensuring that the project is associated with minimal environmental impacts:

- A Phase 2 AIA should be conducted prior to construction commencing and a destruction permit obtained for the medium density MSA scatters (Site EXIGO-SG461-SA02, Site EXIGO-SG461-SA31). Alternatively, the infrastructure should be re-aligned so as not to impact on these resources including a conservation buffer of at least 20 meters.
- Prior to construction commencing, all protected tree species present on the site should be clearly demarcated by an ecologist or suitably qualified person., and if any of these are to be affected by the development, permits should be obtained from the Department of Forestry beforehand.
- The development footprint should be demarcated and kept as small as possible. The demarcated footprint is to avoid areas identified as sensitive in terms of ecological and archaeological aspects.
- Adherence to the provisions of the EMP (Appendix G) should be strictly enforced.

Is an EMPr attached?

YES	NO
----------------	----

The EMPr must be attached as Appendix G.

The details of the EAP who compiled the BAR and the expertise of the EAP to perform the Basic Assessment process must be included as Appendix H.

If any specialist reports were used during the compilation of this BAR, please attach the declaration of interest for each specialist in Appendix I.

Any other information relevant to this application and not previously included must be attached in Appendix J.

NAME OF EAP

SIGNATURE OF EAP

DATE

Section F: Appendixes

The following appendixes must be attached:

Appendix A: Maps

Appendix B: Photographs

Appendix C: Facility illustration(s)

Appendix D: Specialist reports (including terms of reference)

Appendix E: Public Participation

Appendix F: Impact Assessment

Appendix G: Environmental Management Programme (EMPr)

Appendix H: Details of EAP and expertise

Appendix I: Specialist's declaration of interest

Appendix J: Additional Information

Appendix A: Maps

BASIC ASSESSMENT REPORT

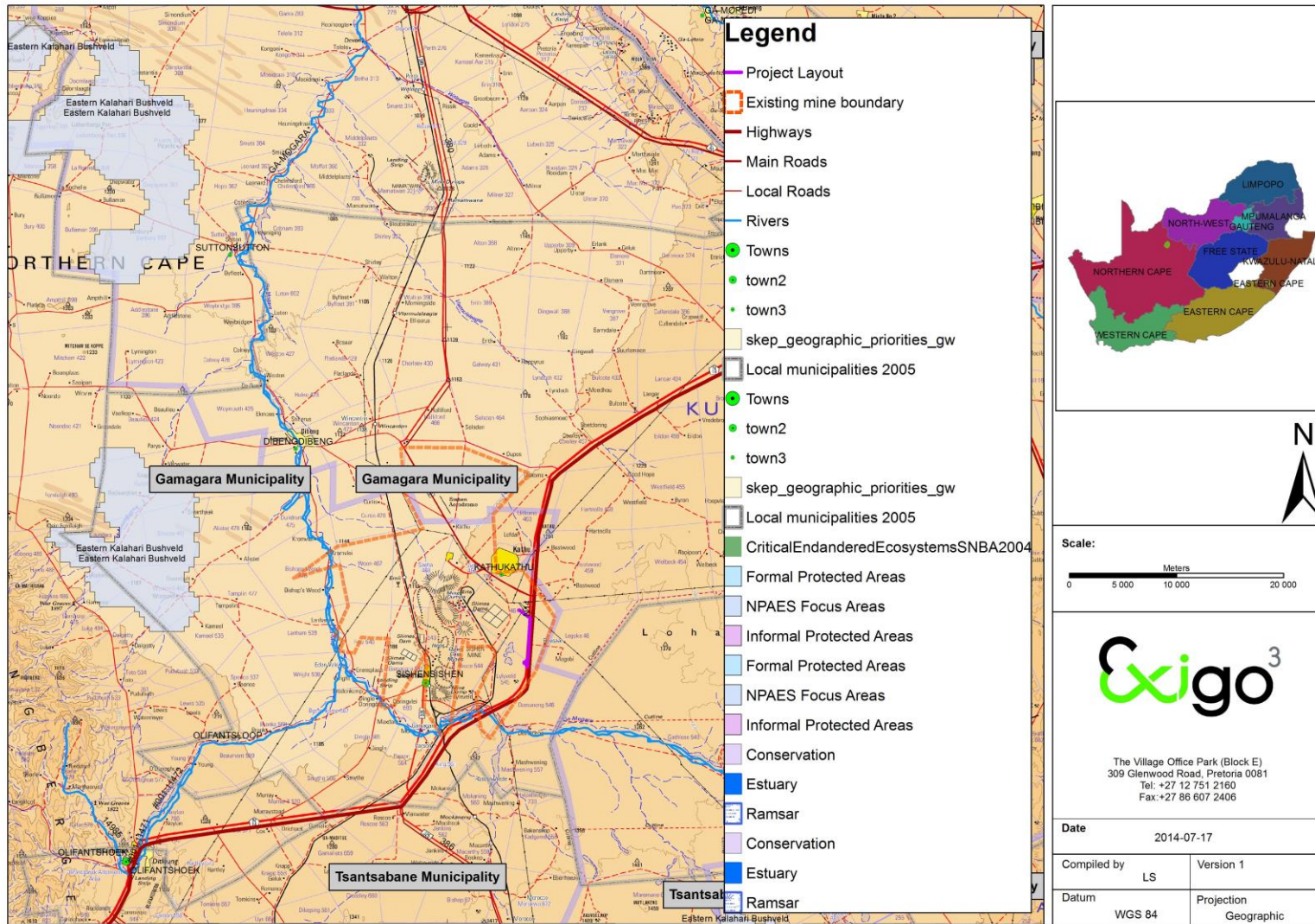

Figure 2: Locality of the Sishen Mine

BASIC ASSESSMENT REPORT

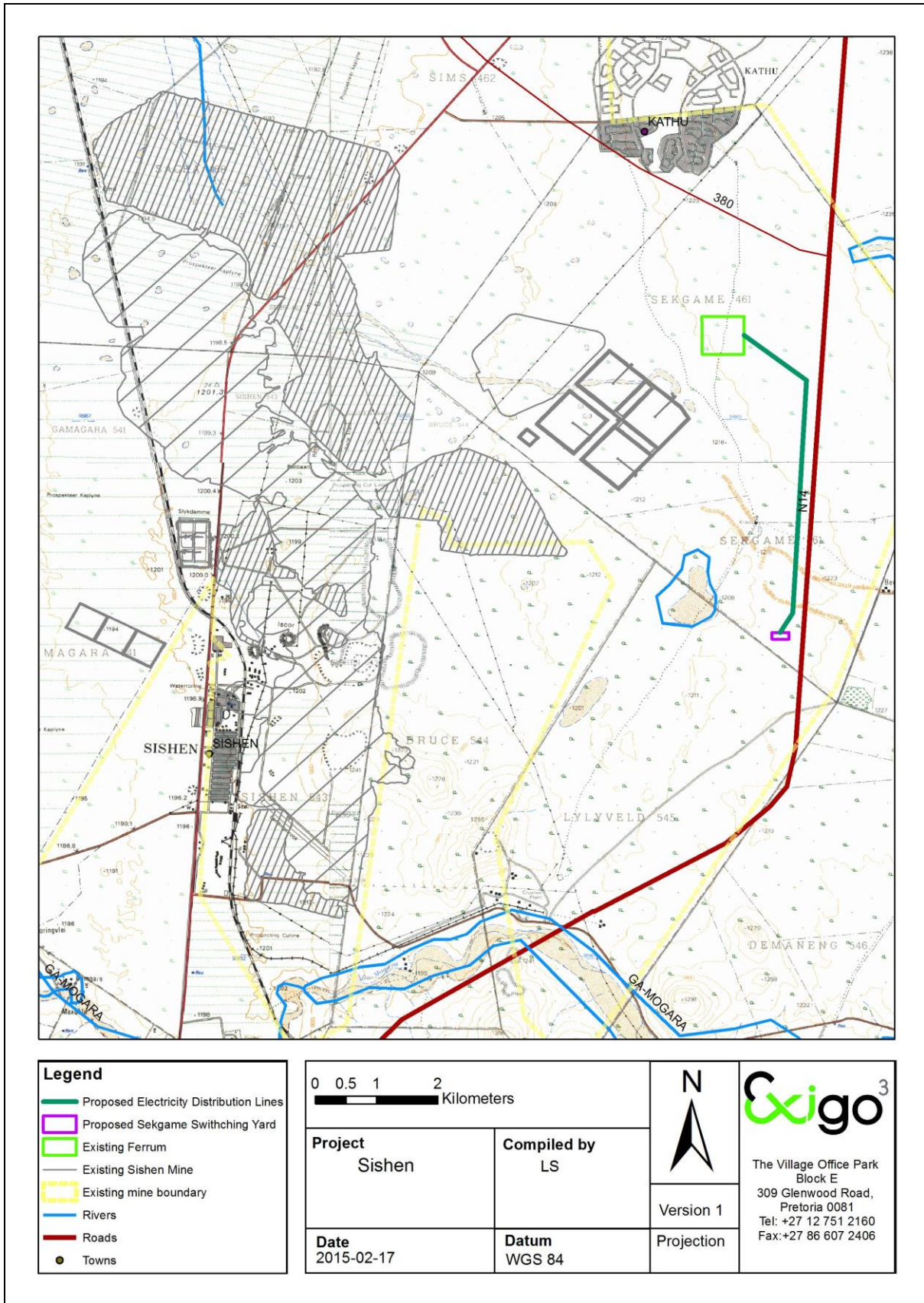

Figure 3: Locality Map - Preferred Alternative

BASIC ASSESSMENT REPORT

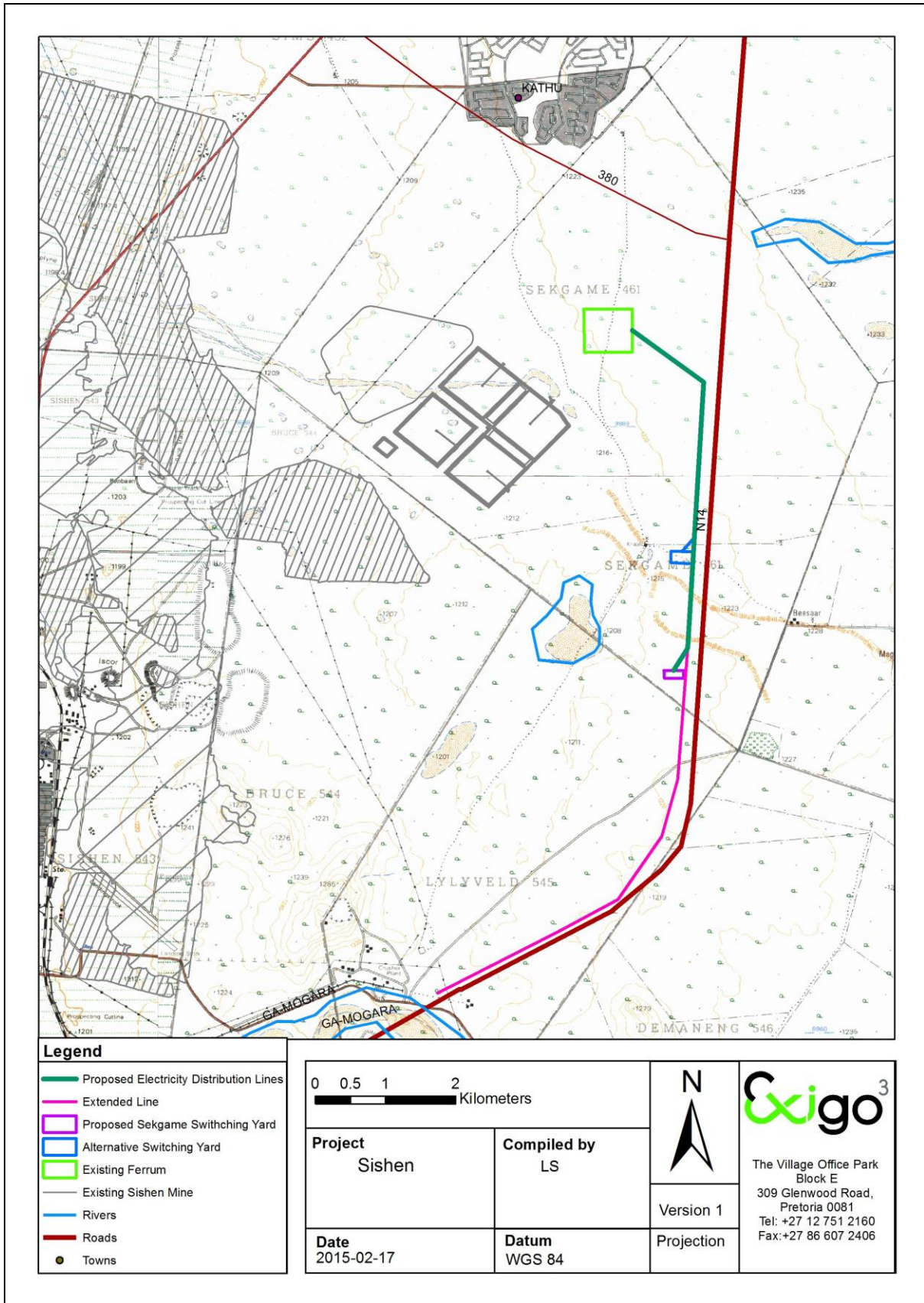

Figure 4: Locality Map showing Alternatives

BASIC ASSESSMENT REPORT

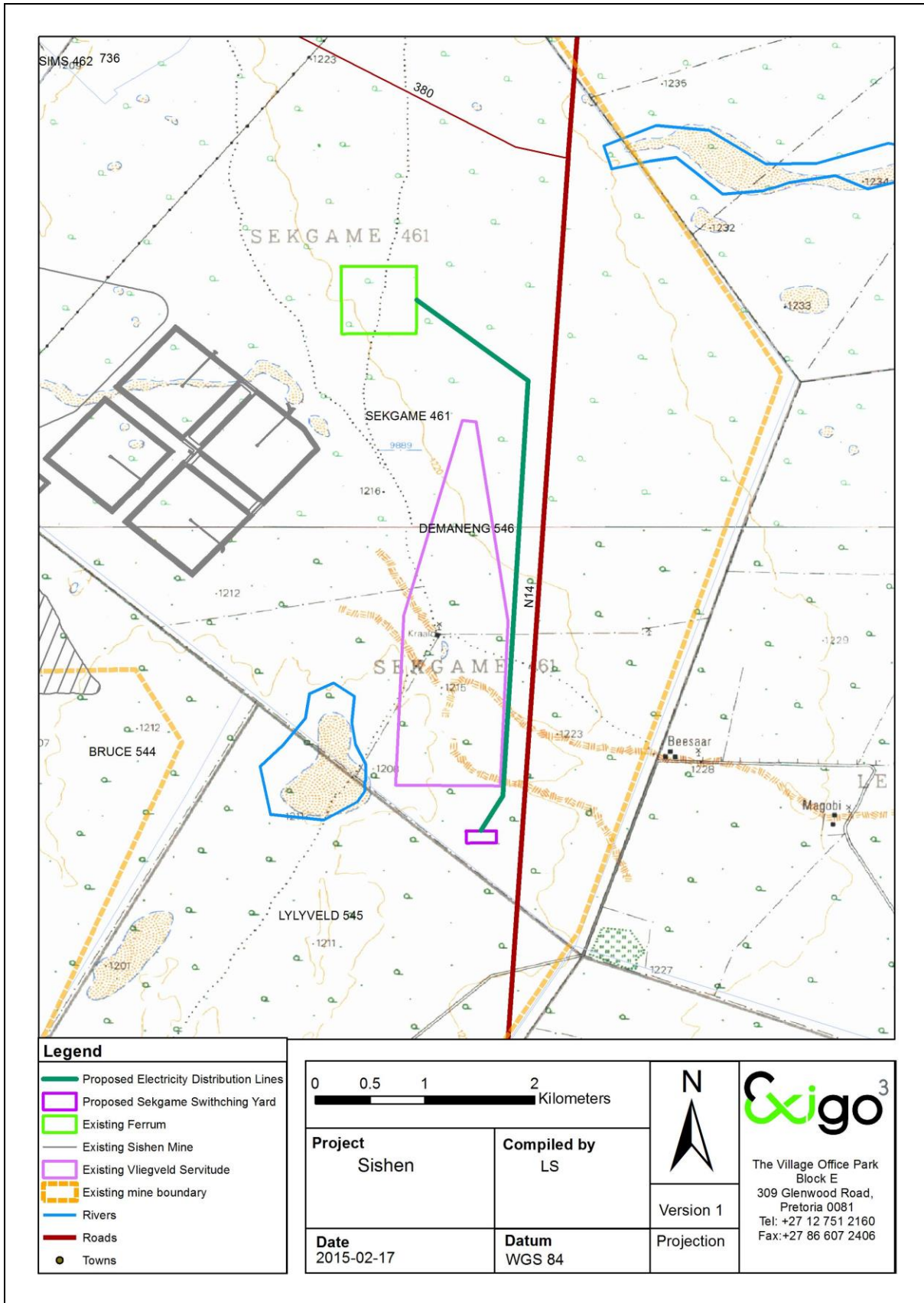

Figure 5: Layout / Route Plan: Preferred

BASIC ASSESSMENT REPORT

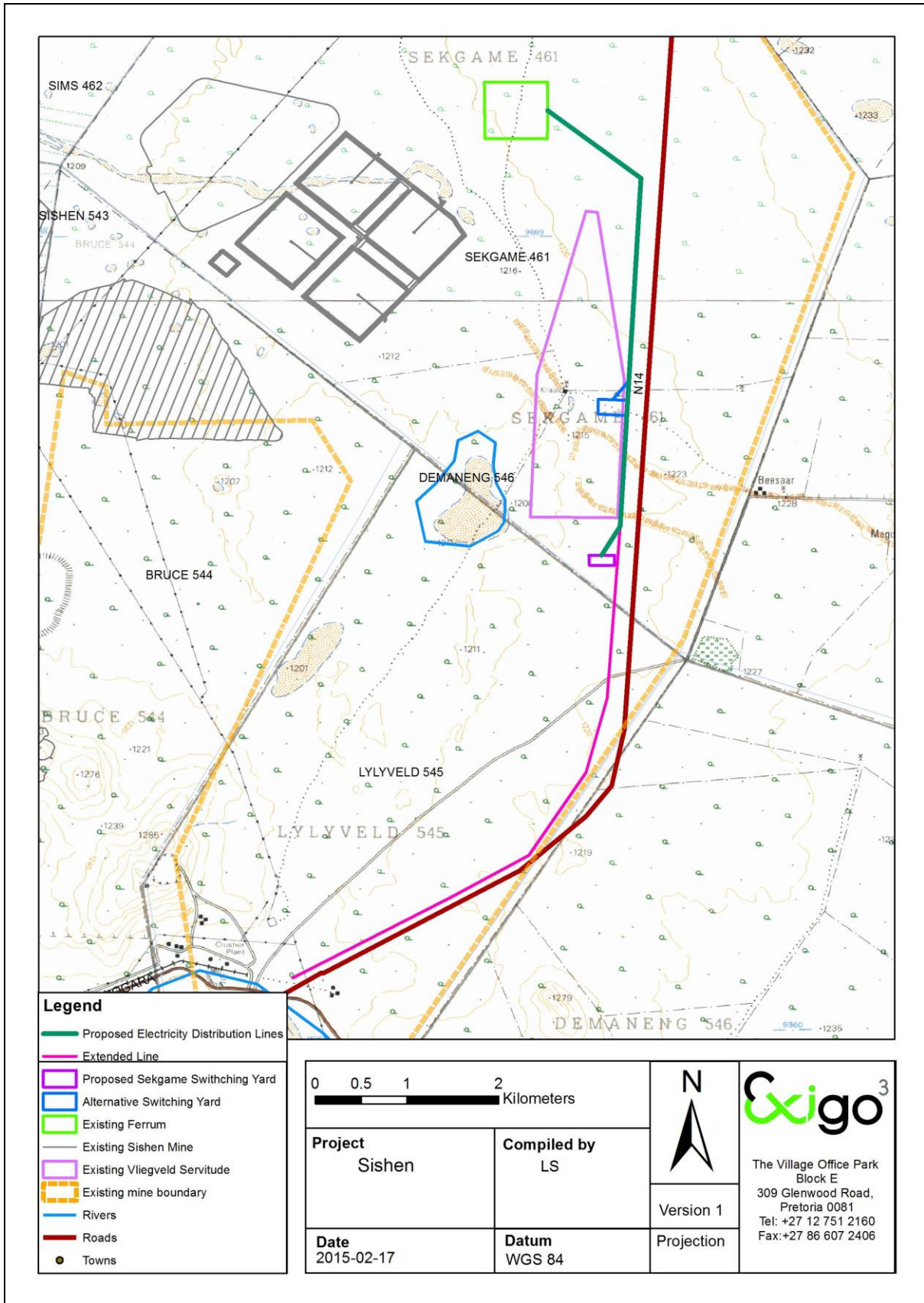

Figure 6: Layout / Route Plan for Alternatives

BASIC ASSESSMENT REPORT

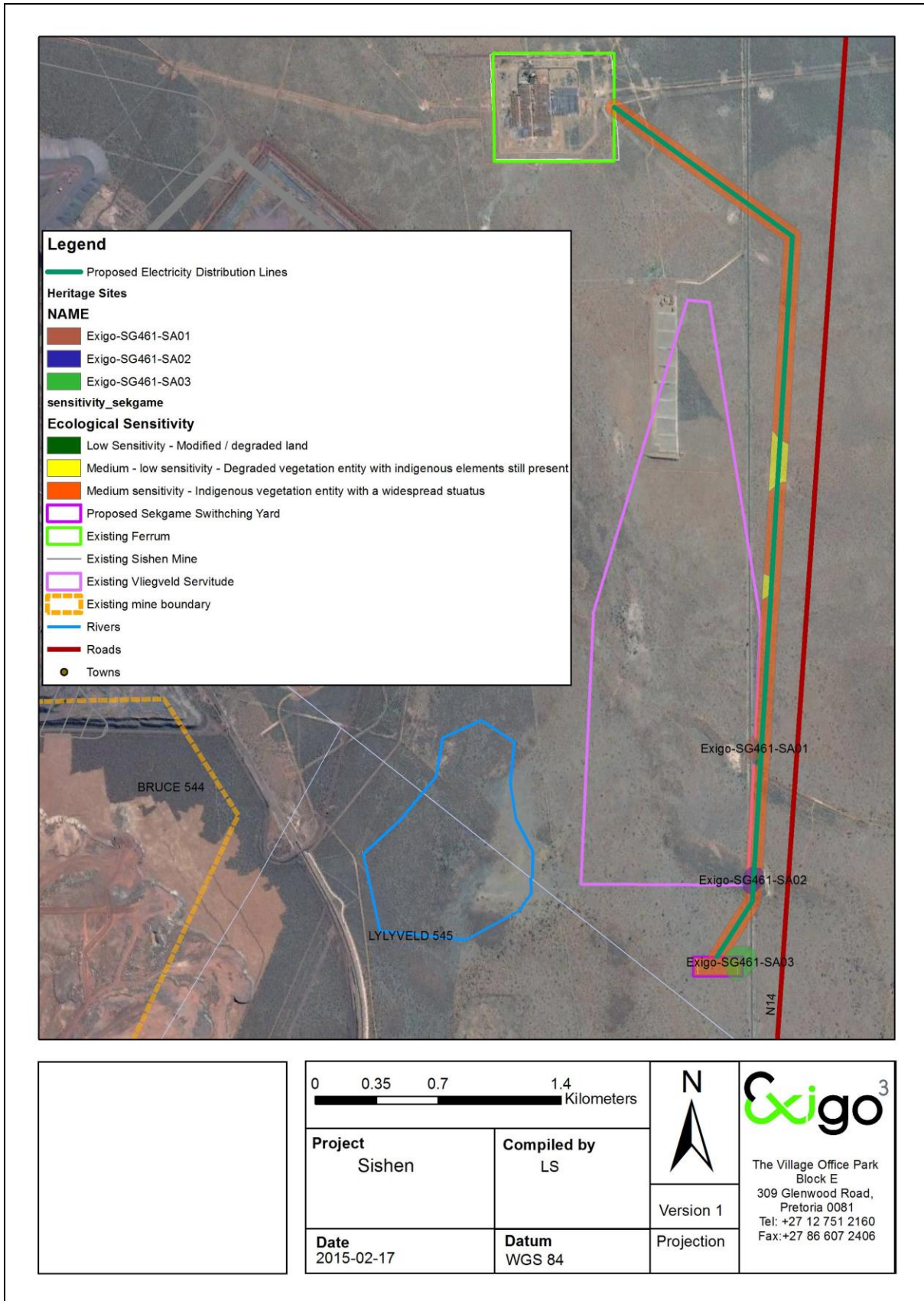
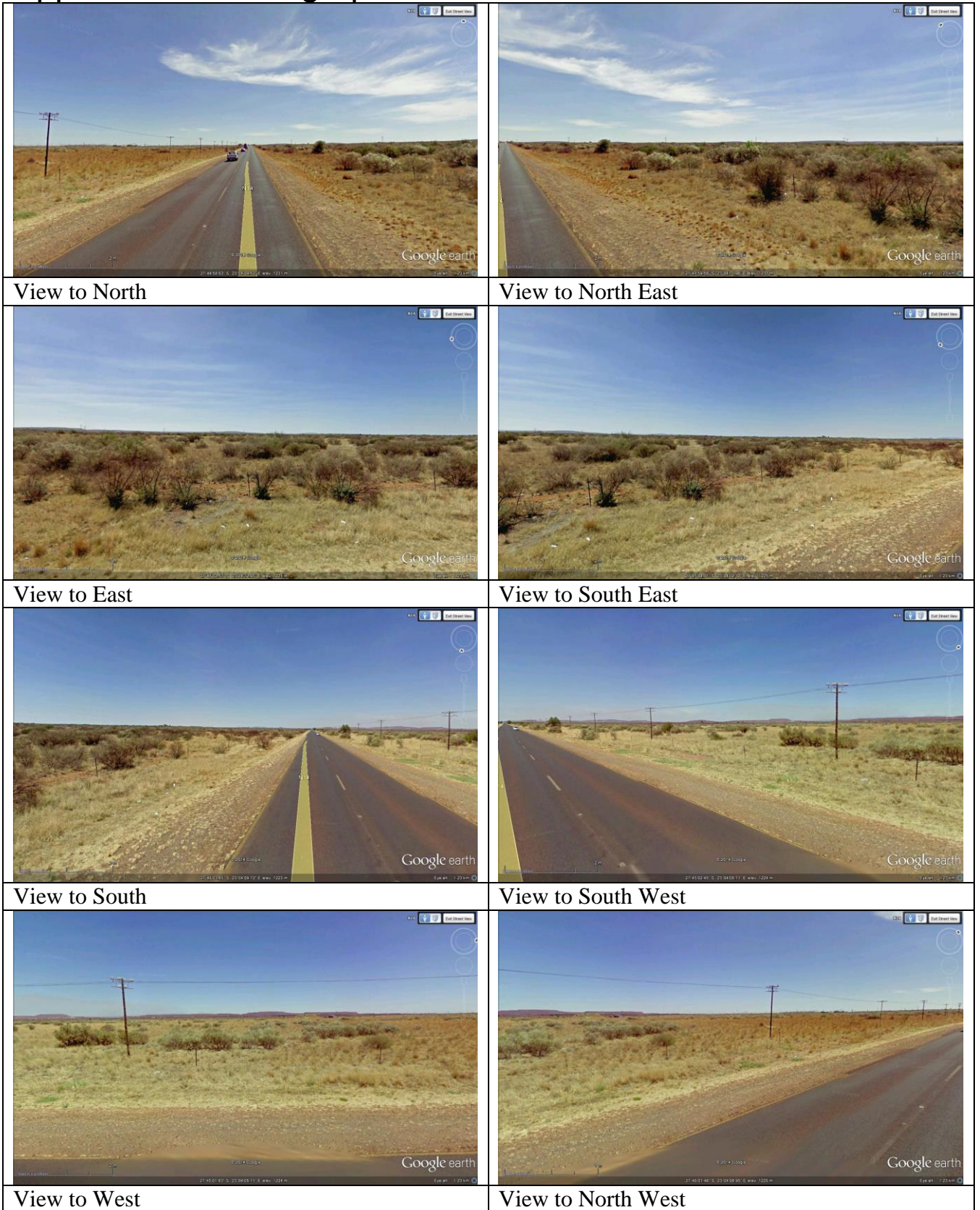

Figure 7: Sensitivity Map

Appendix B: Photographs



Appendix C: Facility illustration(s)

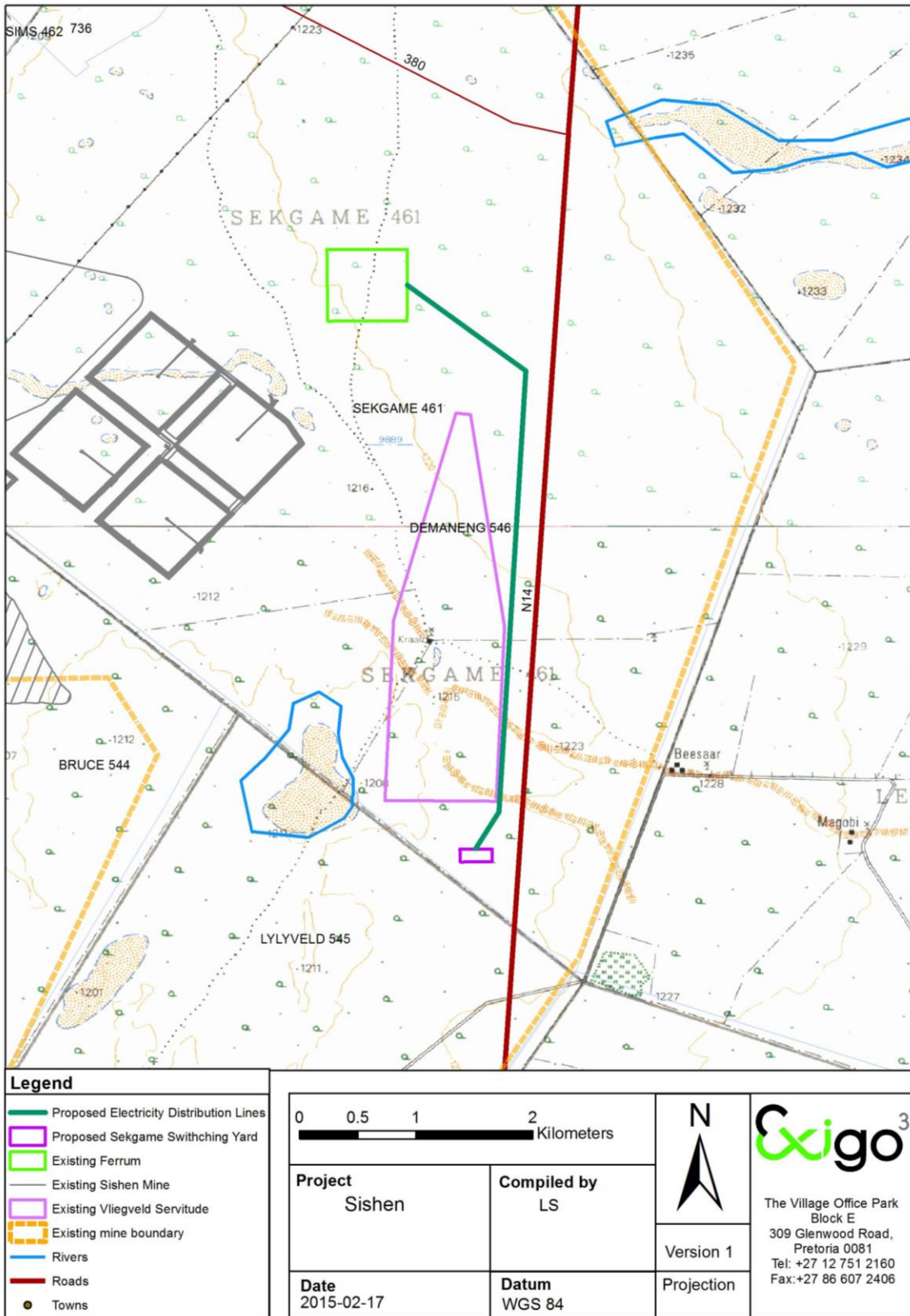

Figure 8: Sekgame Project Layout

BASIC ASSESSMENT REPORT

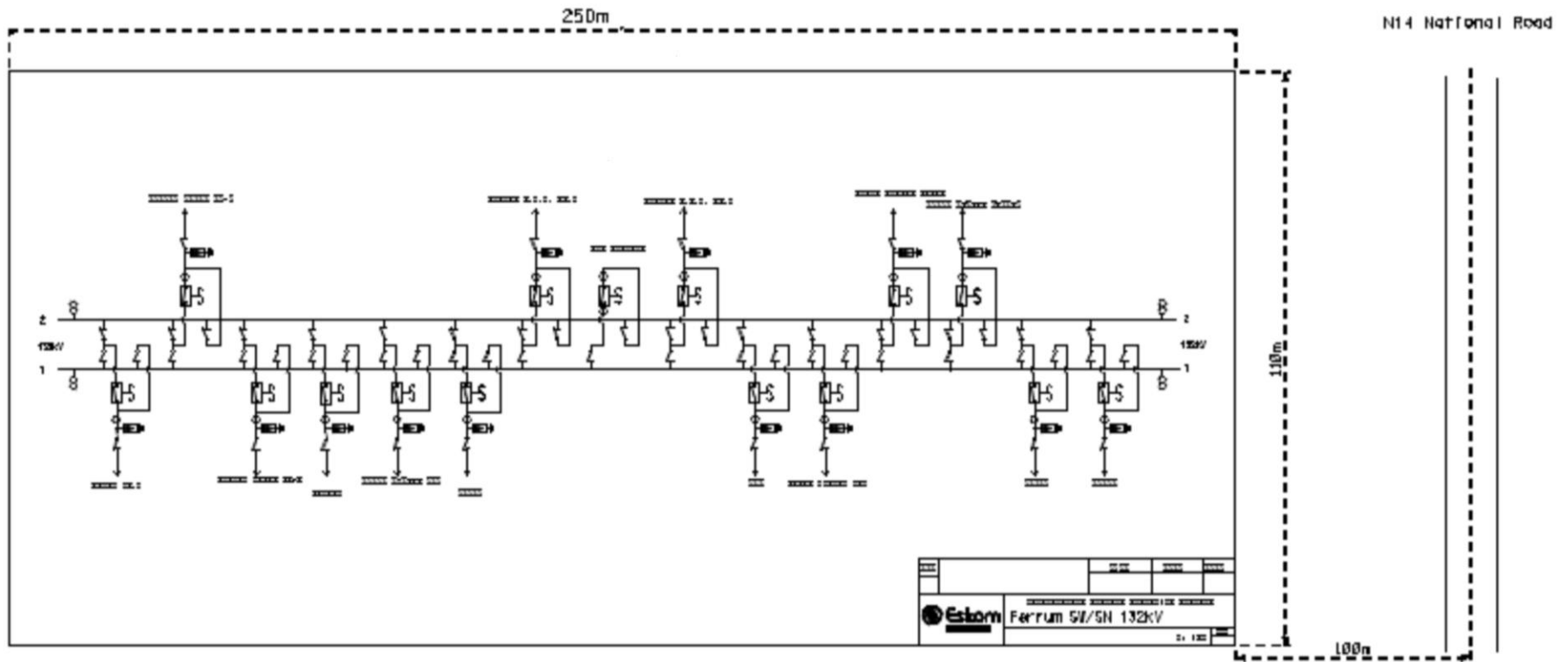

Figure 9: Switching Yard Facility Illustration

Appendix D: Specialist reports (including terms of reference)

Appendix E: Public Participation

Appendix F: Impact Assessment

BASIC ASSESSMENT REPORT

No	Activity/Aspect	Impact	Phase	WM/ WOM	Probability	Duration	Scale	Magnitude	Significance (WOM)	Mitigation	Frequency / responsibility	Significance (WM)						
General Matters																		
				WOM	4	Highly Probable	4	Long Term	3	Regional	8	High						
	The Environmental Management Programme (EMPr)	Understanding and implementation of the EMPr is essential to ensure compliance to relevant legislation and conditions of the authorization (if awarded) as well as to ensure environmental best practice, responsible environmental management and the prevention of pollution and environmental degradation.	Pre-Development															
1				WM	1	Improbable	4	Long Term	3	Regional	2	Low	60	Moderate	<ul style="list-style-type: none"> • The Resident Engineer (RE) will keep a copy of the EMPr and the Environmental Authorisation (EA) at the site during the construction phase • The EMPr must be updated with the conditions contained in the EA. • It will be ensured that all parties employed at the project site are aware of the provisions of the EMPr and that these are legally binding. Employees must be taken through the EMPr and again if there are amendments or when new employees join. • It is recommended that signage explaining the nature of the proposed development, timeframes involved, and contact details of a liaison official must be placed at key public areas around the site. • The layout is captured on the Site Development Plan. Deviations from the Site Development Plan (if approved by the competent authority) should be approved by the Site Manager and the Project Manager (PM). Significant deviations have to be reported to DEA with motivational information and relevant approval sought. 	Environmental Manager and Project Manager Prior to construction	9	Negligible
2	Contractors	The provisions of the	Pre-	WOM	4	Highly Probable	3	Medium	3	Regional	8	High	56	Moderate	<ul style="list-style-type: none"> • The contractor must 	Contractor(s)	8	Negligible

BASIC ASSESSMENT REPORT

4	Environmental Incidents	Regardless of precautionary measures implemented, accidents can still occur at the site and response to accidental pollution or degradation incidents should then limit the impact of the accident	Pre-Development	WOM	2	Probable	3	Medium Term	3	Regional	8	High	28	Low	clearly demarcated <ul style="list-style-type: none"> Records of all environmental incidents must be maintained and a copy of these records be made available to DEA on request throughout the project execution. Emergency response plans should be available on site including spill kits and employees should be trained how to respond to spillages of different types of materials. Confirm suitable sites for the construction camp (equipment and batching etc) and storage areas for materials, as well as site offices. No equipment / materials will be stored in areas not specifically designated for that purpose and approved by the ECO. 	Contractor and ECO prior to construction and throughout construction phase	7	Negligible
				WM	1	Improbable	3	Medium Term	2	Site	2	Low						
5	Training	Personnel on site will not be allowed the "but I didn't know" excuse in the event of environmental degradation or pollution occurring as a result of their activities	Pre-Development	WOM	2	Probable	3	Medium Term	3	Regional	8	High	28	Low	<ul style="list-style-type: none"> Environmental awareness training for construction staff, concerning the prevention of accidental spillage of hazardous chemicals and oil; pollution of water resources (both surface and groundwater), air pollution and litter control and identification of archaeological artefacts will occur prior to construction commencing. Ensure that the training and capabilities of the Contractor's site staff are adequate to carry out the designated 	Contractor, PM, EM and ECO prior to construction with follow-up as necessary	7	Negligible
				WM	1	Improbable	3	Medium Term	2	Site	2	Low						

Appendix G: Environmental Management Programme (EMPr)

Appendix H: Details of EAP and expertise

Appendix I: Specialist's declaration of interest

Appendix J: Additional Information

Table 1: Route Coordinates (refer to the Figure below)

Point No	Latitude	Longitude
Start – Ferrum	27°43'55.01"S	23° 3'43.62"E
Point A - Service Road Crossing	27°44'1.15"S	23° 3'50.60"E
Point B	27°44'10.36"S	23° 4'0.89"E
Point C - Bend	27°44'17.78"S	23° 4'10.54"E
Point D	27°44'35.39"S	23° 4'9.18"E
Point E	27°44'51.71"S	23° 4'8.41"E
Point F	27°45'8.65"S	23° 4'7.10"E
Point G	27°45'30.20"S	23° 4'6.31"E
Point H	27°45'57.40"S	23° 4'4.64"E
Point I – Sekgame Start	27°46'21.87"S	23° 4'2.35"E
Point J – Sekgame End	27°46'45.92"S	23° 4'0.62"E

