



## **ANKERLIG AND GOURIKWA GAS TURBINE POWER STATIONS**

### **Eskom is in the forefront of power generation technology**

Vast and imaginative schemes have assured Eskom's pre-eminence in the energy world and attracted international attention from related specialist sectors. Technical information is the key to a professional understanding of these multi-disciplinary engineering projects.

### **1. OVERVIEW OF THE OCGT POWER STATIONS**

#### **1.1 History**

During 2004 it became apparent that Eskom, as South Africa's electricity supplier of last resort, required a solution with a very short lead time, in order to meet the winter peaks of 2007. After intense investigations the project that was identified as the most viable was that of the Open Cycle Gas Turbine. There were a number of reasons for this:

- The technology was being used extensively all over the world and was readily available
- Stations could be erected, depending on required capacity, in a lead time of 1 – 3 years as opposed to the larger coal and nuclear stations that require 8 – 10 years lead time.
- This type of technology has a proven track record
- There are numerous gas turbine suppliers in the world

#### **1.2 Construction phases**

Sites were selected at Atlantis, near Cape Town, and in Mossel Bay. After consultation with local communities, the power stations were named Ankerlig and Gourikwa. Construction, in each case, was carried out in two phases - on adjacent sites.

##### **1.2.1 Ankerlig Gas Power Station (total capacity 1327 MW)**

The first phase comprised four x 148MW units with a total sent-out capacity of 592MW. Construction began in January of 2006 and was completed in record time by June of 2007.

Started in August 2007, the second phase comprised five additional units with a total capacity of 735 MW. As each machine was completed, during late 2008 and early 2009, it was handed over to Generation Division for commercial operation.

Ankerlig operates as two separate power stations, each with its own control room.

##### **1.2.2 Gourikwa Gas Power Station (total capacity 740MW)**

The first phase comprised three x 148MW units with a total sent-out capacity of 444MW, completed in record time in June 2007.

Started in September 2007, the second phase comprised two additional units with a combined capacity of 296MW. The first unit was synchronized to the grid in September 2008, ahead of time and exactly one year to the day after the turning of the first sod of soil. Phases 1 and 2 operate as one power station.

### **1.3 Role as peaking power stations**

Eskom's new OCGT (Open Cycle Gas Turbine) power stations are powered by liquid fuel (diesel). They are intended to be used during peak periods and emergency situations to supply electricity into the Eskom National Grid.

In addition to generating electricity (Generating Mode), the machines installed during the first phases of each station are able to regulate fluctuations in network voltage (SCO – Synchronous Condenser Mode).

Both Ankerlig and Gourikwa Power Stations are part of Peaking Generation, a business unit in the Generation Division. Peaks in demand are normally between 06:00 and 08:00 in the morning and 17:00 and 20:00 in the evening.

These power stations have similar AC generator technology to that used in modern steam power plants. The turbine is based on industrial gas turbine technology.

An entire unit occupies an area of approximately 75 m x 25 m with the turbine-generator module erected on a reinforced concrete plinth. The turbine-generator and control units are housed in all-weather, painted steel enclosures. The five units of Ankerlig Phase 2 are enclosed in a single, steel clad turbine hall.

### **1.4 Choosing appropriate technology**

During the tender process two dominant reasons led to the selection of the Siemens V94.2 turbine over other competitors. Firstly, they make use of a Low NO<sub>x</sub> Burners, these turbines achieve low NO<sub>x</sub> output without water injection. As the Ankerlig station was to be located in the Western Cape, where water is not always plentiful, this was a very important feature.

Secondly, these units are very robust and able to absorb the stresses of frequent start-ups. This was an important factor as Ankerlig and Gourika would be expected to run during morning and evening peaks, which would mean numerous start-ups.

The open cycle gas turbines are relatively environmentally friendly as they have higher efficiency and burn a cleaner fuel (diesel) than Eskom's coal-fired fleet. Emissions of CO<sub>2</sub> are minimised by the higher efficiency; oxides of nitrogen emissions are controlled by the installation of low NO<sub>x</sub> technology; and emissions of particulates and sulphur dioxide are low. The open cycle gas turbines comply with the Minimum Emission Standards for new plant. The OCGTs can be converted into more efficient, combined cycle gas turbines (CCGTs) if natural gas in sufficient quantities is discovered on the West coast or the utilization factor of the stations reaches 20%.

Natural gas is an ideal fuel and has less environmental impact. It should be noted, however, that approximately 50-60% of OCGT power plants globally use liquid fuels.

### **1.5 Innovation during construction**

Due to a shortage of reserve capacity on the national grid at the time, the OCGTs needed to be built in as short a time as possible. To bring the units onto the grid by the winter of 2007, innovative construction techniques were used, requiring the deployment of numerous contractors on site.

The building of the high voltage (HV) yard at Ankerlig, is one area where an unusual construction method was employed. The area was not levelled in the traditional manner but back-filled, after the foundations had been poured, until the area reached its specified height.

The generating units themselves were built as separate blocks as opposed to a conventional, single building. The value of this was demonstrated by the fact that the first units were commissioned some months prior to the last units, thus putting new capacity onto the grid at the first opportunity.

At both sites, a construction challenge was the tight tolerances on the turbine-generator sets as the civil works needed to be incredibly accurate. For example, the tolerance on the imbedded parts of the turbine was 2 mm over a distance of 13.5 m. This accuracy was achieved by making use of survey equipment accurate to the degree of 1mm/km. The imbedded parts of the generator also had a narrow tolerance of 10 mm. To accomplish this, jacking beams were cast into the generator block on which hydraulic jacks were used to raise the generator into its exact position before the final cast.

The largest foundation required was for the turbine, which weighs 196 tons including the two combustion chambers. For this foundation a continuous pour of 420 m<sup>3</sup> of concrete was used in the first stage. The complete block is made up of 496 m<sup>3</sup> of concrete and 81 tons of reinforcing with the pilings being 6.1 m deep. The total foundation for one power island has 1 998 m<sup>3</sup> of concrete and 107 tons of reinforcing.

## **1.6 Connection to the national electricity grid**

A major component of the project was the integration of the two power stations with the electricity grid. It required the construction of HV Yards, Control Rooms and a number of 400 kV transmission lines.

Gourikwa required two lines of 15 km each to be built, a total of 30 km, ending at the Proteus substation. Ankerlig required four lines of 2 km each and feeds into the existing Koeberg – Aurora 400 kV lines.

Given the urgency of the project, the first phase HV Yards and Control Rooms were built in a record time of eight and a half months, as opposed to the norm of 13 to 16 months.

## **2. OCGT PRINCIPLES**

An OCGT goes through the same process as any internal combustion engine and as such follows the Brayton Cycle. The medium used to drive the turbine is gas and for this cycle there are four main states through which air/gas passes in terms of temperature and pressure.

Air enters the system through the filter housing above the unit and into the air intake, which feeds directly into the compressor blades. A suction effect is created by the compression section of the unit. As the air is compressed and moves forward, it creates a low pressure area behind it. This results in additional air moving into the compression zone. At the same time the air that has already passed through the compressor blades has increased significantly in pressure and slightly in temperature. The next zone through which the air passes is the combustion region where the fuel/air mixture is ignited. As the resultant gas flows through the chamber it is exposed to very high temperatures from the burner flames which increase the temperature further. It is now at a high temperature and pressure and therefore has a large amount of potential energy. The next stage of the cycle is the turbine itself. With its current properties the gas moves quickly through the turbine driving the blades. The final stage is release into the atmosphere through the exhaust stack. Eventually the exhausted gas will return to the same state as the ambient environment.

The shaft through the unit is continuous. When generating mode is established, the rotating turbine blades drive the entire length of the shaft, turning both the compressor blades and the rotor within the generator.

The difference between a combined cycle turbine and an open cycle one is that the hot gas created by the OCGT is simply released into the atmosphere. With a CCGT it is used to heat a boiler which produces steam that drives a turbine/generator set. CCGTs are more efficient as more power is produced without any additional fuel inputs into the system.

## **3. PLANT EFFICIENCY AND RUN-UP**

The two stations have 14 units between them, with a total capacity of 2 067 MW. This capacity, as well as the efficiency of the units (approximately 34% - 36%) is severely influenced by humidity and ambient temperature as well as pressure. Approximately 30% of total engine power is consumed by the compressor for the purpose of air compression.

The start up process is relatively fast with the units able to synchronize with the grid within 5-7 minutes. The time it takes to reach base load is dependent on which loading rate is used as there are three options. The first is the normal rate of 11 MW/min, the second the fast rate at 15 MW/min and the final is the fast, fast rate at 25MW/min, although this is not advised due to the strain it places on the machines. The total time required therefore ranges between 12-20 minutes to reach full load. The rated speed of the shaft is 50 Hz or 3 000 rpm.

In terms of plant efficiency these units have two fuel modes that fulfil the requirements of the turbines at different stages of operation. The first mode that the fuel system enters during start-up is known as diffusion mode. This mode has the advantages of creating a very stable flame and can be used at any output of the machine. The drawbacks are that it is inefficient in terms of fuel consumption and released emissions. Premix mode overcomes these negatives but sacrifices stability to do so. Owing to this, premix can only be used at the upper output ranges of the turbine and a small diffusion flame needs to be maintained, as a pilot light, to ensure the continuity of the premix flame. Diesel is supplied during both of these modes but the difference lies in the fact that the fuel is mixed with air before the combustion zone in premix mode.

#### **4. PLANT OPERATION**

In the South African grid, the main power producing centres are positioned long distances from a number of major development nodes. This means that the power has to be transported long distances, creating instability in the system.

To overcome this, a number of peaking stations within Eskom, including Ankerlig and Gourikwa, have the ability to operate in three modes: standstill, generating and synchronous condenser operation (SCO).

In SCO mode the generators either send out or absorb reactive power (MVARs) in order to regulate the voltage on the transmission system. By exporting MVARs into the system, the voltage is raised. By importing MVARs from the system, the voltage is reduced. The first phase units of both gas stations are equipped with a clutch that allows the rotor to be disconnected from the turbine while in SCO mode.

##### **4.1 Mode Changes**

All mode changes go through very specific steps within the system logic to ensure that all preconditions are adequately met. Modes are Generating, SCO, Turning Gear and Standstill.

###### **- Standstill/Turning Gear to Generating**

The units are very rarely at complete standstill. When not generating or in the SCO mode they are generally in "turning gear". The changes from standstill or turning gear modes to generating are very similar.

When a unit starts up, the generator initially acts as a motor, driving the rotor shaft and therefore the compressor/turbine shaft. This function is performed by the static frequency converter. The SFC draws power to drive the shaft, via the start-up transformer, from the medium-voltage supply of the plant auxiliary power supply system.

As the shaft speeds up the turbine also begins to play a role in accelerating the shaft as the compressor blades begin to set up the vacuum effect which assists in driving the machine. While the unit is still at these relatively low speeds, extra lube oil is pumped into the bearings to provide additional lubrication and reduce the frictional forces that the unit experiences.

When the speed of the unit is between 5.5 – 6.5 Hz the ignition gas system activates and the gas is ignited by two spark plugs located near each burner. These receive their energy from the ignition transformer. The reason that liquid petroleum gas is used to start up the process rather than diesel is simply due to the fact that liquid petroleum gas is more flammable than diesel and is therefore easier to ignite.

Once the burners are running, the turbine begins to play the dominant role in accelerating the shaft. When the shaft reaches approximately 36.5 Hz, the ignition gas valves close and diesel is pumped into the burners. The unit now enters diffusion mode. During this mode only some of the fuel is injected into the burners and the rest is returned via the return line to the storage tanks. This means that there is an opportunity to influence the amount of fuel entering the combustion chamber so that the process can be better controlled.

The benefit of diffusion mode is that it is very stable over the entire output range of the machine. A negative, however, is that the emission levels are much higher when the machine is run in diffusion rather than in premix mode.

The SFC continues to assist in the acceleration of the shaft until it turns at a speed greater than 38.6 Hz. At this point the SFC is shut down and its external isolator is opened. The turbine is now completely responsible for rotating the shaft.

Once the unit is ready to synchronize with the grid the generator breaker closes and the static excitation equipment (SEE) begins to provide energy to the rotor so that the generator can begin to produce power.

Once the unit reaches about 50 % of base load and an output temperature greater than 500°C the unit switches to premix mode. In this mode the fuel enters the burner at a different location which allows it to be mixed with air before the combustion zone. This reduces both the fuel consumption and the emissions.

#### - **Standstill/Turning Gear to SCO**

In SCO mode the generator is operated as a motor to either send out or absorb reactive power from the grid. There are two options by which the generator can be run-up to synchronize with the grid.

The first is to run the unit up using the SFC to a speed greater than 50 Hz. The SFC is then switched off and the machine can synchronize with the grid as the machine slows down naturally.

The second method is to run the unit up in the standard manner with the turbine and then disconnect the turbine from the generator once the unit has linked with the grid. The turbine, however, incurs superfluous equivalent operating hours (EOH). This means that maintenance intervals are reached earlier and required more frequently, which contributes to the running expenses of the unit.

#### - **Generation to Turning Gear/Standstill**

Before the unit can be completely shutdown it is first de-loaded at 11 MW/min to a point below an 8MW output. Once it has reached this level it is further de-loaded until zero MWs are sent out. The reason for de-loading in stages is that it allows the other sub-systems on the unit to complete their own shutdown procedures. When the generator reaches this stage it is disconnected from the grid and the turbine is switched off. The shaft is then allowed to run down naturally until it reaches turning gear speed at which it is rotated for 24 hours to ensure that the shaft and turbine cool down uniformly and that no warping occurs. When the unit is not operating, dehumidified air is circulated through both the turbine and the generator to ensure that any corrosion is kept to a minimum. Ambient air is also prevented from entering the turbine while it is not running so that it does not counteract the dehumidifying system.

## **4.2 Emergency Trips**

Various protection devices are installed to alert the operator to a fault or bring the unit to standstill and prevent damage. Five emergency STOP pushbuttons are installed at appropriate locations to initiate a manual gas turbine trip in the event of an emergency. A gas turbine trip can also be initiated by sensors installed on the unit that monitor temperatures, vibration, pressures, levels and speed. A trip would only be initiated if a specific number of sensors indicate a fault. This makes provision for a faulty reading and to prevent unnecessary trips.

## **4.3 Measuring environmental impact**

The Central Emission Monitoring System (CEMS) on each unit measures the Carbon Monoxide (CO), Nitrous Oxide (NO<sub>x</sub>) and Oxygen (O<sub>2</sub>) emissions. The quantity of other hazardous gases that may be present, such as SO<sub>2</sub>, can be calculated from the chemical composition of the fuel. The reason why the amount of oxygen present is determined is to verify whether or not ambient air has been added to the sample to reduce the concentration of the other gases.

Samples are only taken once a unit has been running for one minute. This is to ensure that any debris in the exhaust stack is released and does not affect the accuracy and credibility of the results.

# **5. TECHNICAL DATA - MAIN PLANT SYSTEMS**

## **5.1 Lube Oil System**

The Lube Oil System has four main functions. Firstly it provides lubricating oil to the bearings along the shaft so as to minimize the friction within, and to remove heat from, the bearings. The lube oil is continually circulated within the system and also ensures that any wear debris or solid contaminants are flushed from the bearings.

Secondly the lube oil is sprayed onto a single-stage hydraulic turbine which is connected to the gas turbine shaft by gearing. This enables the shaft to turn at approximately 2 Hz or 120 rpm at Turning Gear or Barring Speed. This is an important function as it is vital that the shaft is rotated at this speed for 24 hours after being in either synchronous condenser operation (SCO) or generation mode to ensure that the turbine cools down uniformly so that the shaft does not warp.

Thirdly, the Lube Oil System is used to jack the shaft up slightly when the unit is first activated after being at either a very low speed or standstill. The jacking oil is necessary as, at these low speeds, the lube oil in the bearings is not sufficient to create an adequate hydrodynamic lubricating film. The presence of the jacking oil, therefore, helps to further reduce the friction in the bearings, ensuring that the inertia of the shaft can be overcome with less force being required.

Fourthly, lube oil is used by the synchronous condenser clutch to operate its locking control and output brake.

## **5.2 Lube Oil Cooling System**

The lube oil cooling is completed in two stages. The lube oil itself is water cooled through the plate-type heat exchangers that can be found on top of the lube oil skid. This water is in turn air cooled via three fin fan coolers which release the heat into the atmosphere. The system is a closed system, meaning that no additional water is required unless a leak occurs. This system uses demineralised water to ensure that the system is maintained in as new a condition as possible.

## **5.3 Fuel Oil System**

The Fuel Oil System links the Fuel Forwarding System to the turbine to provide the burners within the combustion chambers with fuel oil as well as to remove any fuel that is not burnt. The fuel enters the system at a pressure of between 4 and 7 bar, although it is generally maintained above 6 bar. The fuel is passed through a 10 micron duplex filter before entering the injection pump to remove any debris that could influence the system. The injection pump is a 11 stage centrifugal pump which increases the pressure of the fuel to approximately 80 bar which is required for atomization to take place in the burners. There are three different fuel lines going to and leaving the combustion chambers, namely the diffusion supply and return lines and the premix supply line. Each of these lines has a control valve which ensures that the correct amount of fuel is being injected into the burners.

The Fuel Oil System thus comprises the fuel injection pump, duplex filters and the fuel lines. It also has a fuel oil leakage tank to collect any fuel from the various drain and relief lines in the system.

## **5.4 Purge Water System**

The Purge Water System uses demineralised (demin.) water from the forced reverse osmosis plant on site. The system supplies demin. water at the required pressure to the premix burners whenever the unit changes from diffusion to premix mode or vice versa. The reason for this flushing is to firstly cool off the premix burners before use and then to clean the burners afterwards. This prevents coking and ensures that the nozzles stay clear. The length of each flush on start-up Diffusion-Premix mode, lasts 10 seconds and uses 37,5 litres of water. On shutdown, the Premix-Diffusion mode flush lasts for 20 seconds and uses 75 litres of water.

## **5.5 Hydraulic System**

The Hydraulic System provides pressurized hydraulic fluid for the operation of the position actuators in the auxiliary systems. Predominant of these are the control valves on the fuel lines in the Fuel Oil System. The condition of the hydraulic oil is very important and must remain within the ISO 4406 specifications. For this reason the oil is filtered continuously.

## **5.6 Ignition Gas System**

The Ignition Gas System is responsible for the storage of the ignition gas as well as supplying the gas to the combustion chambers. The gas used on site is 90 - 97 % propane and is contained in two 6.5m<sup>3</sup> tanks at a pressure of 9 – 15 bar. The tanks are, however, only filled to 60 % of their capacity.

## **5.7 Filter Housing**

The air enters the unit through the filter housing situated on the top of the unit. The filter house includes weather hoods, bird screens, pre- and fine filters. The measurement for these filters is 25 micron and 4 micron respectively. The air enters the housing from three sides after which it is fed through silencers into the air intake and then into the compressor.

## **5.8 Turbine**

The turbine is viewed as the portion of the unit that incorporates the air intake, compressor section, combustion chambers, turbine section and diffuser. It is 9.45 m long and 4.1 m in diameter. The compressor section has 16 stages and converts mechanical energy into the kinetic and potential energy of the compressed air. The combustion chambers are silo type chambers and are found on either side of the turbine, weighing approximately 6 tons each. There are eight individual hybrid burners per chamber and both the liquid petroleum (LP) gas and fuel are fed into the same burner, although at different locations. The flame cylinder at the top of each combustion chamber is covered with ceramic tiles, similar to those of space shuttles, to protect the structure from the heat as the temperature ranges from 1 030°C to 1 200°C. There are four sets of turbine blades after which the air passes through to the exhaust. The turbine also incorporates three blow-off pipes which bleed air from the compressor stages and release it via the exhaust to prevent surging in the turbine during start up.

## **5.9 Generator**

The generator is the heaviest single component on site, weighing 223 tons. This component was transported from the North of Germany, via Rotterdam in the Netherlands, through the Suez Canal and down the coast of Africa. The generator has a rated output of 15.75 kV and 6 818 A at 3 000 rpm with a power factor of 0.8.

The rotor conductors are made of copper with a silver content of approximately 0.1 %. This combination increases the strength at higher temperatures to eliminate coil deformation due to thermal stresses. The insulation between the individual turns is made of layers of glass fibre laminate. The field winding consists of several coils connected in series and inserted into the longitudinal slots of the rotor body. The coils are electrically connected in series so that one north and one south magnetic pole are obtained.

## **5.10 Generator Cooling System**

The generators are not 100% efficient, in excess of 2 000 kW being produced in the form of heat. The generators are equipped with indirectly air cooled stator windings and a radial direct air cooled rotor winding. The cooling air for the generator is drawn by axial-flow fans arranged on the rotor via lateral openings in the stator housing. The heat generated in the generator interior is dissipated through air. The rotor is directly air-cooled with heat losses being transmitted directly from the winding copper to the cooling air. Cooling air is supplied at a rate of 50 m<sup>3</sup>/s at 28°C.

## **5.11 Electrical features**

For export onto the national grid, the generator-motor output of 15.75 kV is stepped up to 400 kV by a generator transformer.

Each unit has a generator transformer rated at 186 MVA, operating at 50 Hz. These transformers have a mass of about 135 tons and are filled with 55 tons of oil. They are cooled using an Oil Direct Air Forced (ODAF) cooling system.

Various other voltages are required on site and from the 15.75 kV generator output a unit auxiliary transformer steps the voltage down to 6.6 kV for the unit boards.

In the event that either the generator or auxiliary transformer fails, the unit boards can be interconnected to get a supply from other units. The 6.6 kV system supplies the fuel injection pump.

Backup diesel generators are available to supply all 6.6 kV boards in the event that power from the grid is lost. Their main purpose is to supply energy to essential systems needed to start the gas turbines or to ensure a safe shutdown if power to the gas turbine is lost.

All the transformers, boards and interconnections are controlled and protected by circuit breakers.

## **5.12 Exhaust**

The exhaust stack transfers the hot air from the turbine and releases it into the atmosphere at a maximum temperature of 560°C. The stack is 30 m high and has a diameter of approximately 10 m. The exhaust gas has a mass flow rate of around 520 kg/s and a velocity of approximately 40 m/s.

## **6. TECHNICAL DATA - BALANCE OF PLANT SYSTEMS**

### **6.1 Fuel Off-Loading System**

#### ***Ankerlig:***

As Ankerlig has no direct pipeline to a fuel depot, the fuel is brought in by road tanker and off-loaded at one of the off-loading skids at a rate of between 1 300 -1 400 litres/min.

#### ***Gourikwa:***

Unlike Ankerlig, Gourikwa has a 200 mm pipeline direct from PetroSA to the storage tanks. The length of the pipe is approximately 4.2 km long and can handle a pressure of 1 700 kPa to accommodate the design pressure from the PetroSA side. When the storage tanks on site need to be filled the fuel is pumped at a rate of 180 kl/hr which can, in rare circumstances, be pushed up to 200 kl/hr. As a backup, Gourikwa also has five off-loading skids that can off-load diesel from road tankers at a rate of 1 300 -1 400 l/min.

To remove any air that may be introduced into the system at either Ankerlig or Gourikwa during the off-loading process, the fuel passes through an air eliminator. Once off-loaded the fuel travels through a filter before flowing into one of the storage tanks.

### **6.2 Fuel Storage Tanks**

Storage tanks on both sites each contain approximately 2.7 million litres of diesel. Ankerlig Phase 2 has an additional fuel tank of 5.4 million litres. The storage tanks have both a high level alarm and a low level alarm which trip the off-loading pumps and fuel forwarding pumps respectively. This is to prevent over-filling the tanks and to protect the fuel forwarding pumps and units downstream of the tanks. To keep the pressure on the suction line constant a floating line within the tank is used. This ensures that the end of the pipe is always near the top of the fuel and therefore at constant pressure.

### **6.3 Fuel Treatment System**

The treatment of the fuel is accomplished by passing the fuel through one of four centrifuges on the Alfa Laval skid. Each centrifuge can output 50 m<sup>3</sup>/hr of cleaned fuel to ensure that the units will always have sufficient supply. The centrifuges remove water and water soluble salts, such as sodium and potassium salts, from the fuel. The centrifuges suck fuel from the bottom of the tank as their purpose is to clean the fuel.

### **6.4 Fuel Forwarding System**

The fuel forwarding section of the Balance of Plant comprises the fuel forwarding pumps, a set of filters and a set of coalescers. The three fuel forwarding pumps are variable speed drives (VSDs) so that they have the ability to regulate the pressure in the fuel forwarding pipes between the required 4 – 7 bar. The system is set up such that there is a main, auxiliary and standby pump. This sequence is alternated after each session has come to an end so that the pumps are utilized equally. The three VSDs have a speed of 2 900 rpm and output a flow rate of 284 m<sup>3</sup>/hr. The auxiliary pump is brought into operation when the main pump reaches 40 Hz. After that the load is divided evenly across both pumps so that the frequency is the same for both. From these pumps the fuel passes through both a 30 micron filter and a 5 micron coalescer so that any debris and water can be removed.

### **6.5 Fire Fighting System**

The Fire Fighting System has three different types of pumps to ensure that the water pressure in the lines is always sufficient to meet the requirements on the system. The first pump to activate is the jockey pump which starts when the line pressure is approximately 600 kPa and switches off at approximately 700 kPa. If too much water is being released from the system, the jockey pump will not be able to maintain the pressure on the fire water lines. If the pressure drops further to 500 kPa, the electric fire pump starts up. If the electric fire pump does not activate for any reason and the pressure drops further to 400 kPa then the diesel fire pump comes online. There is a second, redundant signal at 300 kPa to ensure that the diesel pump will start. There are fire sensors throughout the units and general plant area as well as the buildings on site. The response systems are also adapted for each area. For example, the fire system near the fuel skids releases foam rather than water. The fuel bund areas are also covered with foam should a fire break out in these areas.



## 6.6 Reverse Osmosis Plant

Various systems throughout the plant make use of demineralised (demin.) water for their operations. This is produced by the reverse osmosis plant on site. The principle of the system is to pass water through a series of membranes in a form of high pressure filtration so that the correct specifications are achieved. The system can produce 1,5 m<sup>3</sup>/hr. It also incorporates a mixed bed polisher, to further reduce the dissolved solids content in the demin. water, and a 15 m<sup>3</sup> demin. storage tank. The mixed bed system circulates the water from the tank through the cartridges to ensure that the conductivity is constant throughout the tank.

## 6.7 Compressed Air System

The compressed air requirements of the stations are relatively small with the predominant user being the workshop and its pneumatic tools. Compressors on site can each output 750 kPa of air. The compressed air is stored in a reservoir, with a capacity of 1.75 m<sup>3</sup> at a pressure of 750 kPa. Once the pressure in the reservoir drops to 550 kPa or below, one of the compressors will start-up until the pressure is increased to the set-point again.

## 6.8 Potable Water System

The Potable Water System is very simple in that it supplies fire water to the storage tank as well as the general water usage requirements on site. It draws water from the municipal system to supply the needs of the station.

## 7. MAIN CONTRACTORS

Siemens	- Power Island
Roshcon Civil Division	- Civil design, works and buildings
Roshcon Electrical Division	- Electrical cabling, lighting, construction supply and electric fence
Lesedi	- Balance of plant including fire protection, fuel unloading and forwarding, compressed air
IngIntens	- Fuel and water tanks
Diesel Electric	- Emergency diesels
VWS Envig	- Water treatment plant
Sawren	- Ankerlig HV Yard civil works
Ikageng	- Gourikwa HV Yard civil works
Alstom	- 400 kV circuit breakers and isolators
HTSA	- Voltage and current transformers, tubular busbars
ABB	- Gen Breaker, isolators, surge arresters, earth switches, line construction at Gourikwa
Mkhulu	- Line construction at Ankerlig
Graca	- Stringing and cabling at Gourikwa
Cullen Africa	- Composite insulators

## 8. TECHNICAL DATA

### Ankerlig

Number of Units:	9
Output per unit:	
- Phase 1	148 MW
- Phase 2	147 MW
Total Output:	1327 MW

### Gourikwa

Number of Units:	5
Output per unit:	148 MW
Total Output:	740 MW

Synchronizing time:	5-7 minutes
Foundation concrete per Power Island:	1998 m <sup>3</sup>
Reinforcement per Power Island:	107 ton

## **Transformers**

### **Generator Transformer**

Transformer rating:	186 MVA
Operating Frequency:	50Hz
Transformer mass:	135 ton
Transformer oil mass:	55 ton
Voltage Ratio (kV):	420 / 15,75
Cooling:	Oil Direct Air Forced (ODAF)

### **Unit Auxiliary Transformer**

Transformer rating:	12 MVA
Operating Frequency:	50Hz
Transformer mass:	22,5 ton
Transformer oil mass:	4,5 ton
Voltage Ratio (kV):	15,75 / 6,93
Cooling:	Oil Natural Air Natural (ONAN)

### **MV Transformer**

Transformer rating:	740 kVA
Operating Frequency:	50Hz
Voltage Ratio (kV):	6,6 / 0,420
Cooling:	Air Natural (AN)

## **Lube Oil System**

Barring Speed:	120 rpm
Lube Oil reservoir capacity:	56 000 litres
Pump capacity:	164 m <sup>3</sup> /h at 4.5 bar 96 m <sup>3</sup> /h at 5.5 bar
Jacking oil pump capacity:	45 dm <sup>3</sup> /min at 160 bar
Filter type:	20 micron duplex filter

## **Purge Water System**

Flush Length:	10 seconds
Water usage per flush:	80 – 100 litres

## **Ignition Gas System**

Gas:	90-97% Propane
Ignition gas mass flow:	0.13 kg/s
Ignition gas required per ignition:	19 kg
Min. ignition gas supply pressure:	9 bar
Max. ignition gas supply pressure:	15 bar
Ignition gas tank material:	P355NH
Ignition gas tank corrosion allowance:	3 mm
Tank capacity:	6.5 m <sup>3</sup>
Operating pressure:	9-15 bar

## **Filter Housing**

Air filter sizes:	25 micron, 4 micron
-------------------	---------------------

## **Turbine**

Turbine type:	Siemens V94.2
Turbine weight:	196 ton
Turbine length:	9.45 m
Turbine diameter:	4.1 m
Number of stages in turbine compressor:	16
Combustion chamber weight:	approx. 6 ton
Number of burners per combustion chamber:	8
Combustion chamber temperature:	1 030°C - 1 200°C
Foundation concrete per turbine:	496 m <sup>3</sup>

Weight of reinforcement: 81 ton  
Piling Depth: 6.1m

### **Exhaust**

Maximum temperature: 560°C  
Exhaust stack height: 30 m  
Exhaust diameter: 10 m  
Exhaust gas mass flow rate: 520 kg/ s  
Exhaust gas velocity: 40 m/ s

### **Generator**

Output - Voltage: 15.75 kV  $\pm$  5%  
- Current: 6 818 A  
Speed: 3 000 rpm  
Frequency: 50 Hz  
Power Factor: 0.8  
Direction of Rotation: Clockwise (view from generator to turbine)  
Number of poles: 2  
Weight: 223 ton  
Moment of inertia: 7006 kgm<sup>2</sup> (Rotor complete)  
Break away torque - With Pressure Oil: 273 Nm  
- Without Pressure Oil: 22.7kNm  
Bearing losses per bearing: 90 kW

### **Generator Cooling System**

Heat losses: > 2 000 kW  
Cooling air supply rate: 50 m<sup>3</sup>/s  
Cooling air temperature: 28°C

### **Fuel System**

#### ***Fuel Off-Loading System***

##### ***Ankerlig:***

Off-loading method: Tankers, 4 off-loading skids (Phase 1)  
Tankers, 5 off-loading skids (Phase 2)  
Supply rate: 1 300-1 400 litres/min.

##### ***Gourikwa:***

Off-loading method: Direct Pipeline  
Tankers, 3 off-loading skids (Phase 1)  
Tankers, 2 off-loading skids (Phase 2)  
Supply rate: Tankers: 1 300 -1 400 litres/ min  
Pipeline: 3000 litre/min  
Pipeline length: Approx 4.2 km  
Pipeline diameter: 200 mm

#### ***Fuel Storage Tanks: Ankerlig***

Fuel Storage Tank Capacity: 2 x 2.7 million litres (Phase 1)  
1 x 5.4 million litres (Phase 2)  
2 x 2.7 million litres (Phase 2)

#### ***Fuel Storage Tanks: Gourikwa***

Fuel Storage Tank Capacity: 4 x 2.7 million litres

### **Fuel Treatment System**

Fuel Treatment Output: 50 m<sup>3</sup>/ hr

### **Fuel Forwarding System**

Fuel forwarding pressure: 4–7 bar  
VSD speed: 2 900 rpm  
VSD output flow rate: 284 m<sup>3</sup>/hr  
Filter sizes: 30 micron, 5 micron

### **Fuel Injection System**

Pump type: 13 stage centrifugal pump  
Output pressure: 80 bar

### **Fire Fighting System**

System pressure: 600-700 kPa

### **Reverse Osmosis Plant**

Production rate: 1 m<sup>3</sup>/ hr  
Conductivity: < 0.5 μS/ cm  
Storage tank size: 15 m<sup>3</sup>

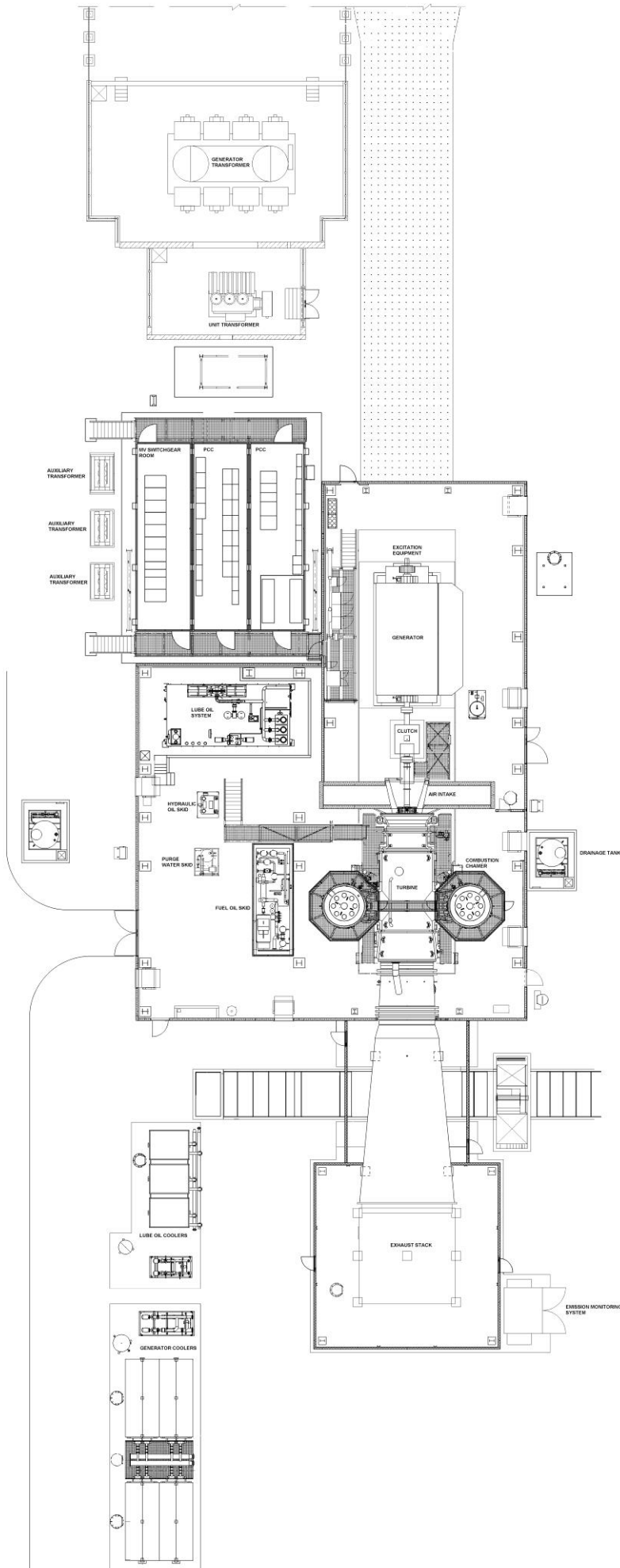

**Gas turbine/generator:  
 Layout of power island**

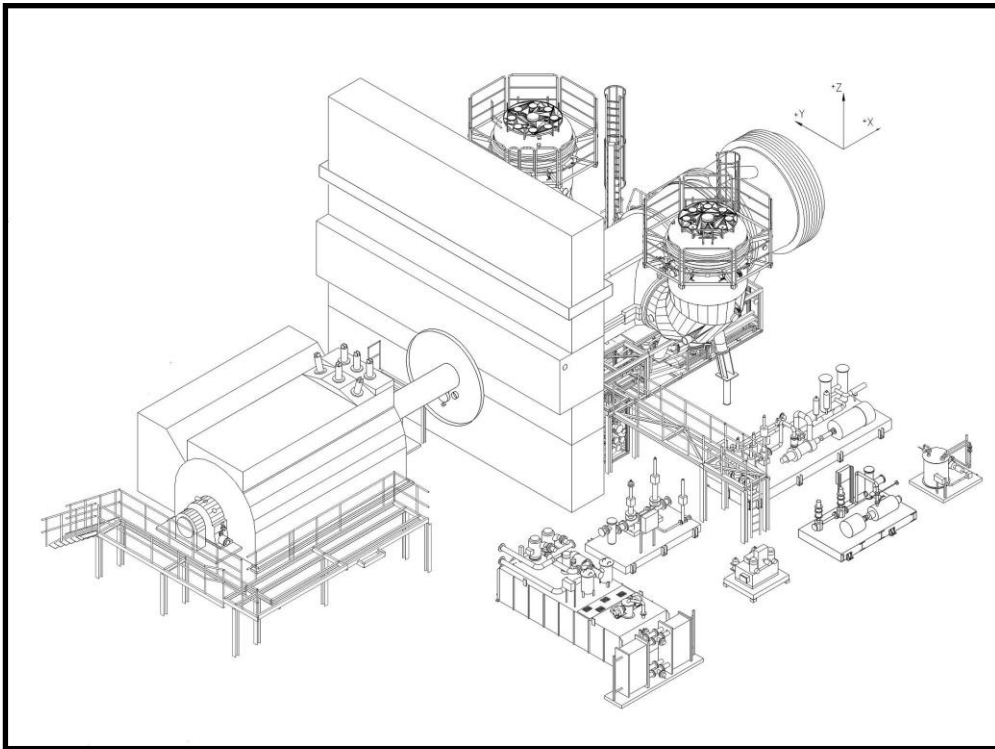

**Generator /  
Turbine layout  
with auxiliaries**

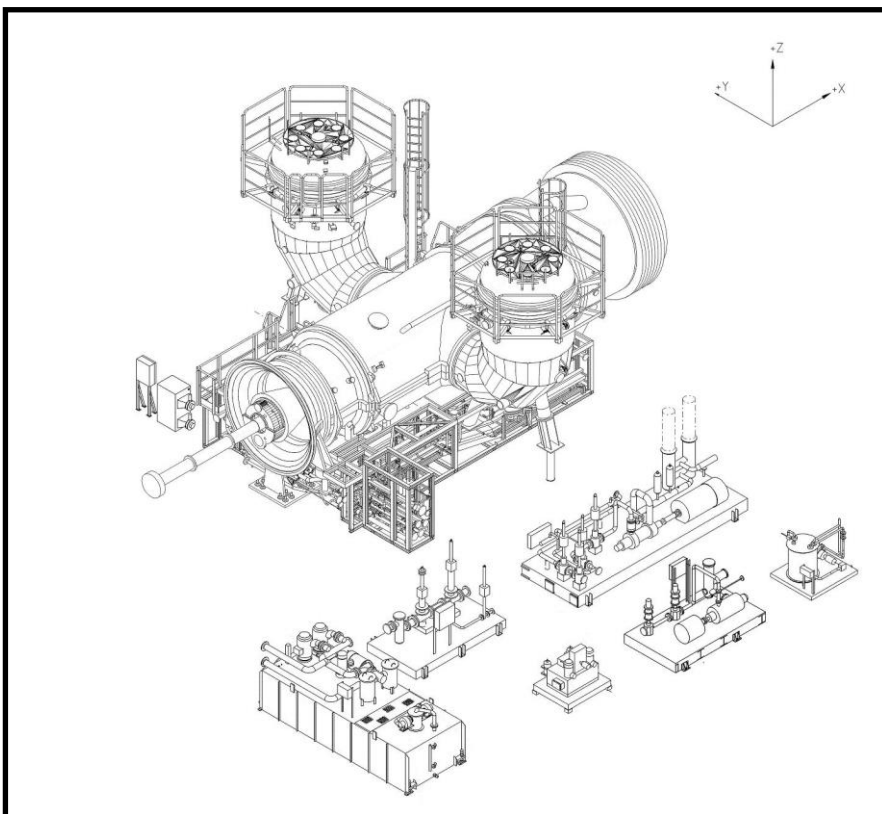

**Turbine with auxiliaries**

**Produced by: Generation Communication  
GS 0003 Revision 7 (November 2017)**

For more information on Eskom related topics see the Eskom website ([www.eskom.co.za](http://www.eskom.co.za)).  
Select "About electricity" and "Facts and Figures"